



**BLUE
CLEAN**®



**CATALOGO CLEANING
DIVISION** *CATALOGUE*



**BLUE[®]
CLEAN**



**DUAL
SERIES**



LA GAMMA COMPLETA AR BLUE CLEAN

I prodotti

Ogni prodotto è descritto in maniera approfondita, soprattutto dal punto di vista delle possibili applicazioni, e corredato da immagini ambientate e video. Nella sezione "Il parere dell'esperto" MR BLUE CLEAN spiega come utilizzare al meglio i prodotti e quali accessori scegliere per ottenere determinati risultati. Un focus particolare è dedicato ai prodotti di punta della gamma, come le idropulitrici Twin Flow.

The products

Each product is described in depth, especially from the point of view of possible applications, and accompanied by set images and videos. In the "Expert opinion" section MR BLUE CLEAN explains how to best use the products and which accessories to choose to obtain certain results. A special focus is dedicated to the leading products in the range, such as the Twin Flow high pressure cleaners.



IDROPULITRICI
HIGH PRESSURE
WASHERS



ASPIRATORI
VACUUM CLEANERS



POMPE AD ACQUA
WATER PUMPS

BLUE CLEAN

Una rete di punti vendita che copre tutto il territorio nazionale, legati al progetto di formazione Demo tour e con merchandising dedicato. Il punto vendita, grazie alle tecnologie che permettono il collegamento con le piattaforme web Blue Clean, si caratterizza come uno spazio dove l'offerta può essere modulata in funzione delle esigenze per intercettare al meglio i bisogni del consumatore finale.



Social

AR BLUE CLEAN è presente sui principali social network come Facebook, Instagram e YouTube dove vengono pubblicati contenuti inerenti al mondo del cleaning a 360°, trattati in chiave moderna e ironica. Il piano editoriale si compone di post di prodotto, rilancio articoli del blog e video dedicati all'intera gamma. Lo scopo è quello di aumentare la visibilità del brand e la viralità dei contenuti, così da portare sempre più persone all'interno del mondo AR BLUE CLEAN.

AR BLUE CLEAN is presents on the main social network such as Facebook, Instagram and YouTube where are posted contents concern the cleaning world treated in a modern and ironic way. The publishing plan sees product post, relaunch of blog's articles and the video of the AR Blue Clean range. The goal is to increase the brand visibility and the contents variety to bring more and more people into the AR BLUE CLEAN world!

Nuovo sito AR Blue

Il nuovo sito AR Blue Clean è online! Completamente rivisitato, ricco delle informazioni necessarie riguardanti i prodotti della gamma di casa Annovi Reverberi e del mondo cleaning. L'inserimento delle sezioni Professional e degli accessori correlati, affiancate a quella Home&Garden, conferiscono la possibilità anche ai professionisti di cercare il prodotto e le specifiche riguardanti i modelli che utilizzano quotidianamente.

POINT

A network of stores located throughout the Italian territory banded to the Demo tour formation and with specific merchandising. The store, which is connected to Blue Clean web platform thanks to a geolocalization system, is the perfect space where the offer can be modified according to the customer needs.

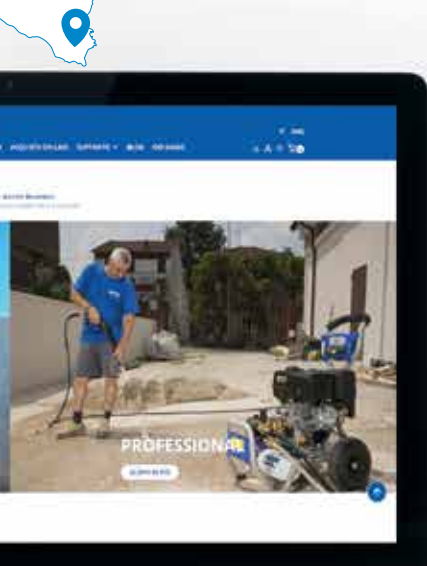

Clean!

The new AR Blue Clean website is online! Totally reviewed and full of information about the Annovi Reverberi cleaning range. The new sections on the Professional range and its accessories, as well as the Home&Garden, allow you to get all the information and the specifications that a professional needs!



10 UTILIZZI ALTERNATIVI DELL'ASPIRAPOLVERE: COME SFRUTTARE AL MASSIMO QUESTO PREZIOSO ELETTRODOMESTICO.



PULIZIE CONDOMINIALI: QUALI SONO GLI STRUMENTI E I MACCHINARI PIÙ UTILI?



COME PULIRE I VETRI SENZA LASCIARE ALONI: TANTI CONSIGLI PER FINESTRE, PORTE E SPECCHI SPLENDENTI



COME RECINTARE UN GIARDINO: QUALI SONO LE PRINCIPALI SOLUZIONI?

Blue Cleaners Blog

Una sezione ricca di suggerimenti, piccoli segreti del mestiere e consigli di pulizia a 360°. Non solo articoli dedicati a come scegliere l'idropulitrice o l'aspiratore più adatto alle proprie esigenze, ma anche approfondimenti relativi alla corretta manutenzione degli spazi home&garden e alle tecniche più avanzate per una pulizia approfondita e professionale senza sforzi.

A section full of suggestions, little secrets of the trade and 360° cleaning tips. Not only articles dedicated to choosing the pressure washer or vacuum cleaner best suited to your needs, but also in-depth information on the correct maintenance of home & garden spaces and the most advanced techniques for a thorough and professional cleaning without effort.

Digital Promo Book

Il volantino digitale promozionale e interattivo, ricco di contenuti multimediali per esplorare le potenzialità e le applicazioni di ogni prodotto AR Blue Clean. Corredato di descrizioni, approfondimenti, applicazioni e tutorial, guida il consumatore finale all'acquisto del prodotto ideale per le proprie esigenze.

DIGITAL PROMO BOOK

The promotional digital book full of multimedia content to describe the AR Blue Clean products potentiality and skills.

Complete with descriptions, insights, applications and tutorials, it helps the consumer to understand which is the perfect product according to his needs.

AVANTI I BLU!



THE POWER OF CLEANING

Tra tutti i marchi della divisione cleaning spicca il brand di casa: **AR Blue Clean**. Un marchio che anno dopo anno, è entrato sempre di più sugli scaffali dei punti vendita più specializzati, in Italia come nel resto del mondo grazie ad una gamma di prodotti completa e perfettamente in linea con le esigenze dell'utilizzatore finale. Un marchio pronto ad individuare soluzioni nel settore del cleaning, riuscendo a mantenere una forte attitudine all'innovazione fortemente legata a logiche produttive e timing stringenti della grande distribuzione.



THE POWER OF CLEANING

*The company's own brand, **AR Blue Clean**, leads the way amongst the cleaning division's many brands. Year by year, the brand has won more and more space on the shelves of the most specialised points of sale, in Italy and throughout the world, thanks to a complete product range, perfectly tailored to the end user's needs. A brand ready to find new solutions in the cleaning industry, sustaining a strong focus on innovation while meeting the tight schedules and times demanded by the retail chains.*



INDICE INDEX

IDROPULTRICI LINEA HOME&GARDEN P 10

Home&Garden line High pressure washers

Applicazioni Applications	P 12
Pompe Pumps	P 14
SERIE SERIES 1	P 18
SERIE SERIES 3	P 20
SERIE SERIES 4	P 22
SERIE SERIES 5	P 24
SERIE SERIES DSS	P 28
SERIE SERIES DHS	P 34
SERIE SERIES DTS	P 38
SERIE SERIES DTS Wi-touch	P 44
SERIE SERIES 7.0	P 48
SERIE SERIES BC250 DSS	P 52
Accessori Accessories	P 58

IDROPULTRICI LINEA PROFESSIONAL P 66

Professional line High pressure washers

PRO COLD	P 67
Applicazioni Applications	P 68
Pompe Pumps	P 73
SERIE SERIES 6	P 85
SERIE SERIES 9	P 94
SERIE SERIES 10	P 100
SERIE SERIES 11	P 108
SERIE SERIES 14	P 109
Accessori Accessories	P 122

PRO HOT P 132

Applicazioni Applications P 134

Pompe Pumps P 136

SERIE SERIES 25	P 142
SERIE SERIES 35	P 142
SERIE SERIES 45	P 142
SERIE SERIES 56	P 144
SERIE SERIES 58	P 145
SERIE SERIES 66	P 146
SERIE SERIES 69	P 147
SERIE SERIES 78	P 148
SERIE SERIES 88	P 149
SERIE SERIES 13	P 150

Accessori Accessories P 152

ASPIRATORI VACUUM CLEANERS P 158

Applicazioni Applications P 160

SERIE SERIES 31 P 164

SERIE SERIES 32 P 165

SERIE SERIES 33 P 166

SERIE SERIES 36 P 167

SERIE SERIES 37 P 168

E12 P 170

M20 P 171

VACUUM CLEANERS PRO P 172

Applicazioni Applications P 174

SERIE SERIES 41 P 178

SERIE SERIES 42 P 179

SERIE SERIES 43.44 P 181

SERIE SERIES 47 P 185

SERIE SERIES 48 P 186

SERIE SERIES 42L P 187

SERIE SERIES 43L P 188

SERIE SERIES 49 P 189

Accessori Accessories P 190

POMPE WATER PUMPS P 200

Applicazioni Applications P 205

SERIE SERIES ARGP 600P P 208

SERIE SERIES ARGP 800X P 209

SERIE SERIES ARGP 1100X P 210

SERIE SERIES ARGP 600PB P 214

SERIE SERIES ARGP 800XB P 215

SERIE SERIES ARGP 1100XB P 217

SERIE SERIES ARUP 250PC P 220

SERIE SERIES ARUP 400PC P 220

SERIE SERIES ARUP 750XC P 221

SERIE SERIES ARUP 750PT P 222

SERIE SERIES ARUP 1100XD P 225

Accessori Accessories P 226

MERCHANDISING P 230

LOGISTIC DATA P 236

HOME & GARDEN

Una gamma di prodotti studiati nei minimi dettagli per assicurare facilità di utilizzo ed estrema affidabilità nell'ambiente domestico. Idropultrici ideali per tutta la famiglia, versatili e leggere diventano lo strumento di pulizia ottimale per rimuovere lo sporco da vialetti, balconi, auto, biciclette e moto e diventano strumenti indispensabili per gli appassionati di giardinaggio. Perfette anche per rimuovere, senza fatica, il muschio e le incrostazioni del tempo dalle recinzioni o dagli arredi da esterno, per la pulizia del patio vicino a piscine e per gazebo e lettini solari. E' per questo che ARBC fa la differenza: ha la soluzione ideale per ogni tipo di esigenza.

A range of products designed down to the tiniest detail to ensure ease of use and extreme reliability in the home.

Ideal high pressure washers for all the family: versatile and light weight, they are excellent for removing dirt from paths, balconies, cars, bicycles and motorbikes, and are an essential tool for gardening enthusiasts.

They are also perfect for effortlessly removing moss and deposits left by time from fences or outdoor furniture, and cleaning poolside patios, gazebos and sunbeds.

This is why ARBC makes a real difference: it has the right solution for every type of need.



Applicazioni ed indicatori di prestazioni Home & Garden

Home & Garden performance Indicators & Applications

BLUE CLEAN LEVEL

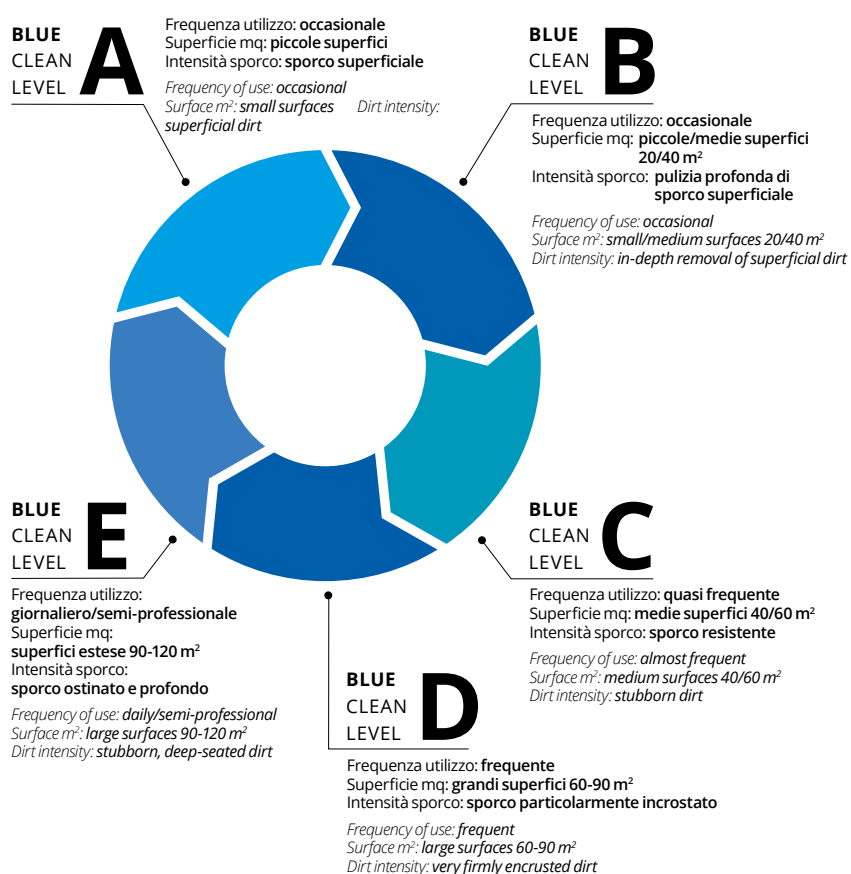

BLUE CLEAN LEVEL ti guida nella scelta del prodotto migliore, in base ad ogni esigenza di pulizia, affiancando ad ogni idropulitrice o aspiratore un'icona di livello lavaggio, insieme con le applicazioni. Ogni prodotto ha le sue caratteristiche tecniche ma anche estetiche-funzionali per soddisfare specifiche necessità del cliente, come la facilità d'uso, la compattezza, l'ergonomicità, il peso, la rumorosità e la manovrabilità. Grazie al Blue Clean Level suggeriamo ad ogni cliente la combinazione migliore: è per questo che i prodotti ARBC fanno la differenza.

BLUE CLEAN LEVEL guides you in the choice of the best products for all cleaning needs, by placing a cleaning level icon next to every high pressure washer or vacuum cleaner, together with its applications. Every product has its own technical, stylistic and functional characteristics, to satisfy specific customer requirements, such as ease of use, compact size, labour-saving, weight, noise output and agility. With Blue Clean Level we direct every customer towards the ideal combination: this is why ARBC products make a real different.

BLUE CLEAN FACTOR



La combinazione ideale tra prestazioni tecniche e configurazione commerciale per poter risolvere al meglio le tue esigenze di pulizia. I prodotti che hanno il BLUE FACTOR sono i migliori, all'interno della loro categoria, per poter pulente, facilità d'utilizzo e prestazioni tecniche. Il mix perfetto per ogni tua esigenza di pulizia.

The ideal combination of technical features and commercial configuration, to deliver the best solution to your cleaning needs. Products with the BLUE FACTOR are best-in-class in cleaning power, ease of use and technical performances. The perfect mix for all your cleaning requirements.



HOME & GARDEN APPLICATIONS

cancellate fencing	panchine benches	giardino garden	biciclette bicycles	moto motorcycle	disinfestazione pest control
auto cars	camper recreational vehicles RV's, campers	barche boats	pavimenti flooring, paving stones	scale stairs	gardening gardening
piscine pools	utensili tools	casa house	muri walls	tetti roofs	sanificazione sanitizing

Le idropulitrici della gamma Home & Garden sono la soluzione perfetta per la pulizia degli spazi domestici ed esterni: dimezzano i tempi di pulizia, rendendo il lavoro semplice e di facile esecuzione, grazie anche ad un'ampia selezione di accessori studiata per i diversi campi di applicazione. Ne è un esempio il patio con serbatoio detergente incorporato, ideale per la pulizia di ampie superfici quali terrazze e bordi piscina, che ottiene risultati uniformi e brillanti alla prima passata! Le potenti lance con getto rotopower assicurano invece il miglior risultato sull'arredo da esterno, che costantemente esposto alle intemperie è spesso aggredito da sporco ostinato, con un semplice gesto.

Home & Garden range high pressure washers are the perfect solution for cleaning spaces inside and outside the home: washers halve cleaning times, making the whole process simple and easy - thanks also to a wide range of accessories designed for the various fields of use. One example is the patio version, with integral detergent tank, ideal for cleaning large areas such as patios and swimming pool surrounds, which provides gleaming, uniform results in a single pass! In another application, the powerful lances with rotopower jet at the appropriate pressure setting ensure the best results on outdoor furniture, which is constantly exposed to the weather and often accumulates stubborn dirt, with the greatest of ease.

1 Series																			
117	●	●	●	●															
143	●	●	●	●															
3 Series																			
387	●	●	●	●	●					●	●	●		●					
397	●	●	●	●	●					●	●	●		●					
4 Series																			
491					●	●				●	●	●	●	●	●				
5 Series																			
589						●	●	●	●	●	●	●	●	●	●	●	●		
591						●	●	●	●	●	●	●	●	●	●	●	●		
DSS Series																			
2.0 PE	●	●	●	●	●	●	●	●	●	●	●	●	●	●	●	●	●		
3.0 PE	●	●	●	●	●	●	●	●	●	●	●	●	●	●	●	●	●		
DHS Series																			
2.A	●	●	●	●	●					●	●	●		●				●	●
DTS Series																			
4.0 TF	●	●	●	●	●	●	●	●	●	●	●	●	●	●	●	●	●		
5.0 TF	●	●	●	●	●	●	●	●	●	●	●	●	●	●	●	●	●		
DTS Wi-Touch Series																			
4.1	●	●	●	●	●	●	●	●	●	●	●	●	●	●	●	●	●		
7.0 DPS Series																			
7.0						●	●	●	●	●	●	●	●	●	●	●			
BC250 DSS																			
	●	●		●	●	●	●												

Pompe

Pumps

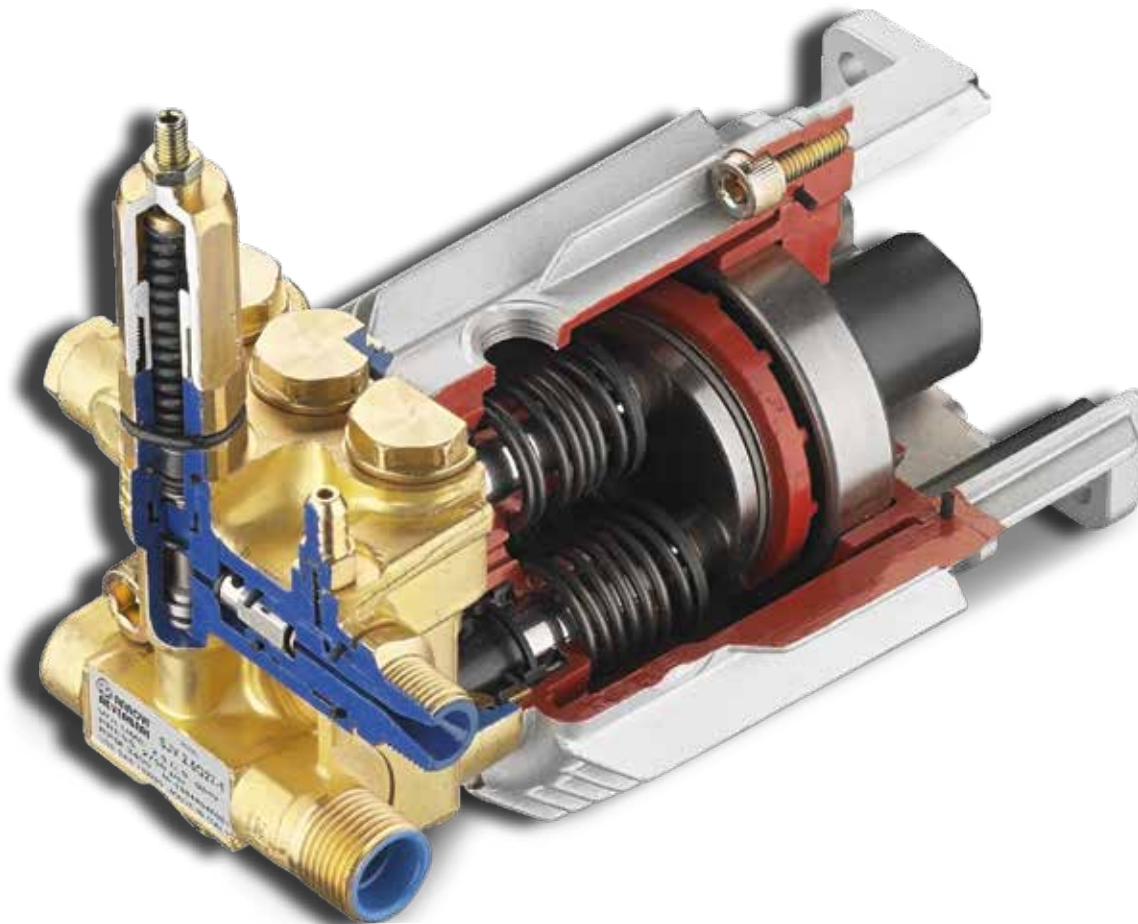

Pompa a piattello oscillante di dimensioni ridotte per utilizzo sia ad asse orizzontale che verticale.
Corpo pompa realizzato in lega d'alluminio per un'alta resistenza.
Il piattello oscillante è sempre realizzato in lega d'alluminio con un particolare trattamento antiusura. I componenti interni sono tutti di dimensioni maggiorate in grado così di garantire una buona affidabilità anche in condizioni di lavoro particolarmente gravoso.

*Compact wobble-plate pump for use both horizontal and vertical.
Aluminium alloy pump body for high strength. The wobble plate is also in aluminium alloy with a special wear-resistant coating. Internal components are all oversized, to guarantee excellent reliability even in particularly heavy-duty conditions.*

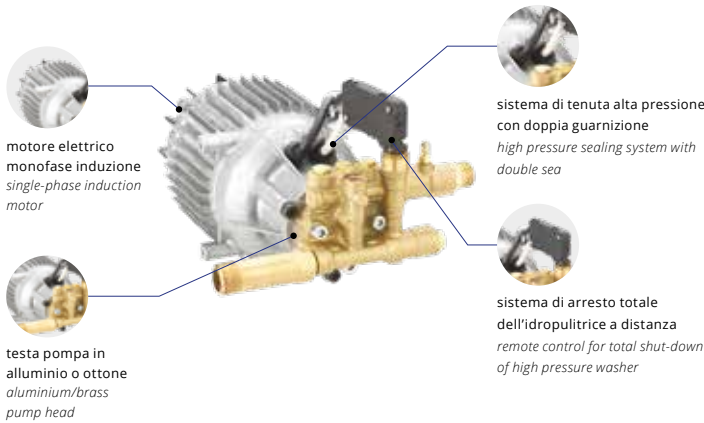

- Pompa a 3 pistoni assiali comandati dal piattello oscillante, testa alluminio
- Pistoni in acciaio inox temperato
- Valvola di sicurezza automatica che diminuisce la pressione residua, agevola l'azionamento della leva pistola e riduce l'affaticamento della mano
- Motore elettrico monofase con protezione termica
- Sistema di arresto totale dell'idropulitrice a distanza
- Aspirazione acqua da serbatoio con funzione autoadescente

- 3 Axial stainless steel pistons wobble-plate pump with aluminium head
- Tempered stainless steel pistons
- Automatic safety valve that decreases the residual pressure, facilitates the operation of the gun lever and reduces hand fatigue
- Single-phase motor with thermal protector
- Remote control for total shut-down of high pressure washer
- Inlet water suction from tank by self priming function

- Pompa a 3 pistoni assiali comandati dal piattello oscillante
- Pistoni in acciaio inox temperato
- Testa pompa in alluminio (Mod.491)
- Testa pompa in ottone (Mod.589/591/7.0)
- Valvola di sicurezza automatica che diminuisce la pressione residua, agevola l'azionamento della leva pistola e riduce l'affaticamento della mano (mod. 491)
- Motore elettrico monofase a induzione con protezione termica
- Sistema di arresto totale dell'idropultrice a distanza
- Sistema di tenuta alta pressione con doppia guarnizione (mod. 589/591/7.0)
- Aspirazione acqua da serbatoio con funzione autoadescente

- 3 Axial stainless steel pistons wobble-plate pump
- Tempered stainless steel pistons
- Aluminium pump head (Mod.491)
- Brass pump head (Mod.589/591/7.0)
- Automatic safety valve that decreases the residual pressure, facilitates the operation of the gun lever and reduces hand fatigue (mod. 491)
- Single-phase induction motor with thermal protector
- Remote control for total shut-down of high pressure washer
- High pressure sealing system with double seal (mod. 589/591/7.0)
- Inlet water suction from tank by self priming function



POMPE / PUMPS



	1300 WATT	1500 WATT	1900 WATT	2200 WATT	2500 WATT	2500 WATT	2700 WATT	2100 WATT	2500 WATT	2800 WATT
117	●									
143		●								
387			●							
397				●						
491								●		
589									●	
591										●
2.0				●						
3.0					●					
2.A DHS				●						
4.0 TF						●				
5.0 TF							●			
4.1 WiTouch						●				
7.0										●





SERIE 1	P 18
SERIE 3	P 20
SERIE 4	P 22
SERIE 5	P 24
DUAL RANGE	p.26
BC250 DSS	p.52



1 Series 117

IDROPULTRICI ALTA PRESSIONE
high pressure washers



porta accessori
built-in accessories
holder



filtro ingresso acqua
ispezionabile
inspectable water
intake filter



portatile
portable



dispositivo click -fast
click-fast connection drive



Caratteristiche Generali

- Pompa a 3 pistoni assiali comandati dal piattello oscillante, testa in alluminio
- Pistoni in acciaio inox temperato
- Valvola di sicurezza automatica con azzeramento della pressione nella testa pompa
- Protezione termica del motore
- Serbatoio detergente

General Features

- 3 Axial stainless steel pistons wobble-plate pump with aluminium head
- Tempered stainless steel pistons
- Automatic by-pass valve with pump head pressure discharge
- Motor thermal protector
- Detergent tank

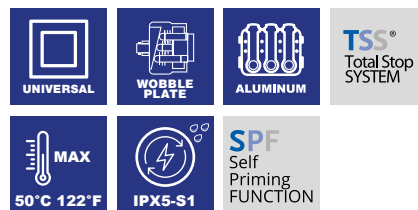

MOD	COD	MAX		MAX					KG NET
		bar	psi	l/h	gph	kW	Hz	V	kg
117	13689	110	1600	390	103	1,3	50-60	220-240~	5,6

Accessori standard Standard accessories



41559

41563

41564



46348
(3 m)



41570





Caratteristiche Generali

- Carrello a 2 ruote completo di manico
- Pompa a 3 pistoni assiali comandati dal piattello oscillante, testa in alluminio
- Pistoni in acciaio inox temperato
- Valvola di sicurezza automatica con azzeramento della pressione nella testa pompa
- Protezione termica del motore
- Ugello rotante
- Serbatoio detergente

General Features

- Two-wheel trolley with handle
- 3 Axial stainless steel pistons wobble-plate pump with aluminium head
- Tempered stainless steel pistons
- Automatic by-pass valve with pump head pressure discharge
- Motor thermal protector
- Rotay nozzle
- Detergent tank



MOD	COD	MAX		MAX					KG NET
		bar	psi	l/h	gph	kW	Hz	V	kg
143	13690	120	1740	390	103	1,5	50-60	220-240~	5,9



Accessori standard Standard accessories





3 Series 387

IDROPULTRICI ALTA PRESSIONE
high pressure washers



TRADE SELECTION



Caratteristiche Generali

- Carrello a 2 ruote completo di manico
- Pompa a 3 pistoni assiali comandati dal piattello oscillante, testa alluminio
- Pistoni in acciaio inox temperato
- Valvola di sicurezza automatica con azzeramento della pressione nella testa pompa
- Protezione termica del motore
- Tubo alta flessibilità (6 m)
- Ugello rotante
- Serbatoio detergente

General Features

- Two-wheel trolley with handle
- 3 Axial stainless steel pistons wobble-plate pump with aluminium head
- Tempered stainless steel pistons
- Automatic by-pass valve with pump head pressure discharge
- Motor thermal protector
- Super flexible hose (6 m)
- Rotary nozzle
- Detergent tank



MOD	COD	MAX		MAX					KG NET
		bar	psi	l/h	gph	kW	Hz	V	kg
387	15458	150	2175	420	110	1,9	50-60	220-240~	7

Accessori standard Standard accessories



46328 46332 46541 (6 m)

47339 41565 46540



NEW



TRADE SELECTION

Caratteristiche Generali

- Carrello a 2 ruote completo di manico ed avvolgitubo
- Pompa a 3 pistoni assiali comandati dal piattello oscillante, testa in alluminio
- Pistoni in acciaio inox temperato
- Valvola di sicurezza automatica con azzeramento della pressione nella testa pompa
- Protezione termica del motore
- Tubo alta flessibilità (6 m)
- Ugello rotante
- Serbatoio detergente

General Features

- Two-wheel trolley with handle and hose reel
- 3 Axial stainless steel pistons wobble-plate pump with aluminium head
- Tempered stainless steel pistons
- Automatic by-pass valve with pump head pressure discharge
- Motor thermal protector
- Super flexible hose (6 m)
- Rotary nozzle
- Detergent tank

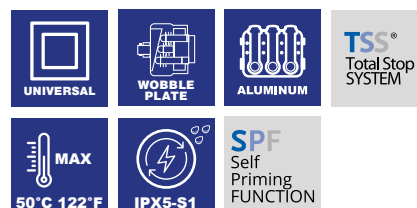

MOD	COD	MAX		MAX		MAX			KG NET
		bar	psi	l/h	gph	kW	Hz	V	kg
397	15459	160	2320	460	121	2,2	50-60	220-240~	7,6

Accessori standard Standard accessories





4 Series 491

IDROPULTRICI ALTA PRESSIONE
high pressure washers



manico ergonomico
ergonomic handle



avvolgitubo in pressione
in pressure hose reel

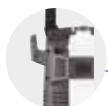

porta accessori
built-in accessories holder



serbatoio detergente integrato
built-in detergent tank



battistrada in gomma
rubber wheels



filtro ingresso acqua ispezionabile
inspectable water intake filter

Caratteristiche Generali

- Carrello a due ruote completo di manico ed avvolgitubo
- Pompa a 3 pistoni assiali comandati dal piattello oscillante
- Pistoni in acciaio inox temperato
- Valvola di sicurezza automatica con azzeramento della pressione nella testa pompa
- Motore elettrico monofase a induzione con protezione termica
- Aspirazione detergente diretta con serbatoio incorporato
- Capacità del serbatoio detergente 1,4 l
- Tubo rinforzato con treccia in acciaio (8 m)
- Accessori con interno in metallo
- Ugello rotante

General Features

- Two-wheel trolley with handle and hose reel
- 3 Axial stainless steel pistons wobble-plate pump
- Tempered stainless steel pistons
- Automatic by-pass valve with pump head pressure discharge
- Single-phase induction motor with thermal protector
- Built-in detergent tank for direct suction
- Detergent tank capacity 1.4 l
- Steel braided hose (8 m)
- Accessories with inner metal parts
- Rotary nozzle

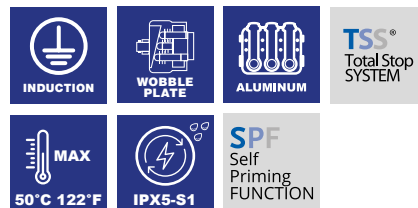

MOD	COD	MAX		MAX						KG NET
		bar	psi	l/h	gph	kW	rpm	Hz	V	kg
491	13694	145	2100	450	119	2,1	2800	50	220-240~	21,5

Accessori standard Standard accessories



41571

41572
(46 cm)

41575
(43 cm)



43987
(8 m)







5 Series 589

IDROPULTRICI ALTA PRESSIONE
high pressure washers



TRADE SELECTION



manico telescopico
telescopic handle

avvolgitubo in pressione
in pressure hose reel

porta accessori
built-in accessories holder

schiumogeno alta pressione
high pressure foam lance

battistrada in gomma
rubber wheels

filtro ingresso acqua ispezionabile
inspectable water intake filter

regolazione della pressione
pressure adjustment

Caratteristiche Generali

- Carrello a due ruote completo di manico ed avvolgitubo
- Pompa a 3 pistoni assiali comandati dal piattello oscillante
- Pistoni in acciaio inox temperato
- Valvola di sicurezza automatica con azzeramento della pressione nella testa pompa
- Manometro
- Motore elettrico monofase ad induzione con protezione termica
- Regolazione della pressione
- Ugello rotante
- Tubo rinforzato con treccia in acciaio (10 m)

General Features

- Two-wheel trolley with handle and hose reel
- 3 Axial stainless steel pistons wobble-plate pump
- Tempered stainless steel pistons
- Automatic by-pass valve with pump head pressure discharge
- Pressure gauge
- Single-phase induction motor with thermal protector
- Pressure adjustment
- Rotary nozzle
- Steel braided hose (10 m)



MOD	COD	MAX	MAX					NET		
		bar	psi	l/h	gph	kW	rpm	Hz	V	kg
589	14989	170	2500	500	132	2,5	2800	50	220-230~	24,4

Accessori standard Standard accessories



46575

46576

46578

46580

46581 (10m)





TRADE SELECTION

Caratteristiche Generali

- Carrello a due ruote completo di manico ed avvolgitubo
- Pompa a 3 pistoni assiali comandati dal piattello oscillante
- Pistoni in acciaio inox temperato
- Valvola di sicurezza automatica con azzeramento della pressione nella testa pompa
- Manometro
- Motore elettrico monofase ad induzione con protezione termica
- Regolazione della pressione
- Ugello rotante
- Tubo rinforzato con treccia in acciaio (10 m)

General Features

- Two-wheel trolley with handle and hose reel
- 3 Axial stainless steel pistons wobble-plate pump
- Tempered stainless steel pistons
- Automatic by-pass valve with pump head pressure discharge
- Pressure gauge
- Single-phase induction motor with thermal protector
- Pressure adjustment
- Rotary nozzle
- Steel braided hose (10 m)



MOD	COD	MAX	MAX					NET		
		bar	psi	l/h	gph	kW	rpm	Hz	V	kg
591	14990	180	2600	600	159	2,8	2800	50	220-230~	25

Accessori standard Standard accessories



DUAL RANGE

Un'intera gamma di idropultrici dotate di tecnologie DUAL studiate e brevettate Annovi Reverberi. Grazie alla doppia funzione incorporata, questi modelli sono in grado di coprire un ampio range di applicazioni, con performance modulabili in base all'esigenza. Ciascuna tecnologia e' infatti appositamente studiata per soddisfare ogni esigenza mantenendo una forte attitudine all'innovazione tecnologica. Potenti, versatili, maneggevoli e durature. Scopri tutta la gamma DUAL RANGE!

"DUAL RANGE" is the range of AR BLUE CLEAN high pressure washers with built-in double function resulting from the combination of ANNOVI REVERBERI technologies and patents. The DUAL RANGE has been made for fulfilling the outdoor needs covering a wide range of applications thanks to their DUAL function. Each technology has been developed to satisfy the customer's needs. Powerful, versatile, manageable and durable. Discover the entire DUAL RANGE!



SERIE DSS	P 28
SERIE DHS	P 34
SERIE DTS	P 38
SERIE WT	P 44
SERIE 7.0	P48

DUALSPEED SYSTEM

DSS è l'innovativo sistema tecnologico che consente di modulare la performance della idropulitrice attraverso l'utilizzo di un comodo selettore. Le prestazioni del sistema possono essere così selezionate in base alle necessità di utilizzo: la modalità MAX SPEED consente di approfittare di tutta la potenza dell'idropulitrice per soddisfare le richieste più esigenti, la modalità ECO SPEED permette invece di ridurre del 30% il consumo di energia quando le richieste di potenza lavante sono meno rilevanti.

DSS is the innovative technological system which allows you modulating the pressure washer's performance through the use of a convenient selector. The performance of the system can thus be selected based on the needs of use: the MAX SPEED mode allows you to take advantage of all the power of the high-pressure cleaner to meet the most demanding requirements, the ECO SPEED mode can reduce by 30% of the energy consumption when washing power demands are less relevant.

2.0 DUAL SPEED

2
DSS
DUAL SPEED
SYSTEM

NEW

1 ECO SPEED
30% ENERGY SAVING
■■■■■■■■■■■ 

2 MAX SPEED
FULL PERFORMANCE
■■■■■■■■■■■





Sistema a doppia velocità.

Dual speed system.

Tramite il POWER SWITCH è possibile selezionare le modalità **ECO SPEED WASHING** e **MAX SPEED WASHING** e modulare il livello di performance dell'idropulitrice adeguandolo ad esigenze di pulizia più leggera, con un notevole risparmio di acqua e di energia (fino al 30%), o più intense in funzione del lavoro da svolgere.

*Using the POWER SWITCH it is possible to select the **ECO SPEED WASHING** and **MAX SPEED WASHING** modes, to modulate the performance level of the pressure washer, adapting it to lighter cleaning needs, with a considerable saving of water and energy (up to 30%), or more intense depending on the work to be done.*

30% ENERGY SAVING



ECO SPEED

30% ENERGY SAVING

Attivando la modalità **ECO SPEED** puoi dedicarti alla pulizia di sporco non aggressivo su superfici esterne in legno, biciclette, mobili da giardino in legno, tessuti esterni, con un **consumo energetico ottimizzato** e un miglior compromesso tra efficacia del lavaggio/consumi.

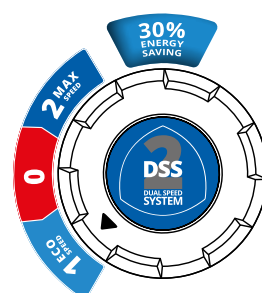

*By activating **ECO SPEED** mode you can dedicate yourself to cleaning non-aggressive dirt on external wooden surfaces, bicycles, wooden garden furniture, external fabrics, with **optimized energy consumption** and a better compromise between washing / consumption effectiveness.*



MAX SPEED

FULL PERFORMANCE

Attivando la modalità **MAX SPEED** puoi dedicarti invece alla pulizia di sporco aggressivo su pietra, cemento e mattoni, ringhiere e cancelli in metallo, attrezzi da lavoro e da giardinaggio, automezzi con un **consumo energetico standard**.

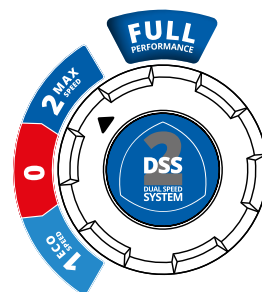

*By activating **MAX SPEED** mode you can dedicate yourself to cleaning aggressive dirt on stone, concrete and bricks, metal railings and gates, work and gardening tools, vehicles) with **standard energy consumption**.*



avvolgitubo statico con tubo alta flessibilità 6 m
static hose reel with super flexible hose 6 m

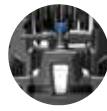

schiumogeno alta pressione
high pressure foam lance



battistrada in gomma
rubber wheels



selettore rotativo a 3 posizioni off/Eco Speed/Full Speed
3 positions rotative switch off/Eco Speed/Full Speed



dispositivo click -fast
click-fast connection drive



Caratteristiche Generali

- Manico con avvolgitubo statico per
- Pompa a 3 pistoni assiali comandati dal piattello oscillante, testa in alluminio
- Pistoni in acciaio inox temperato
- Valvola di sicurezza automatica con azzeramento della pressione nella testa pompa
- Motore universale a due velocità con protezione termica
- Lunghezza cavo elettrico 5 m
- Ugello rotante
- Lava superfici Ø250 mm

General Features

- Two-wheel trolley with handle and static hose reel
- 3 Axial stainless steel pistons wobble-plate pumps
- Tempered stainless steel pistons
- Automatic by-pass valve with pump head pressure discharge
- Dual speed single-phase universal motor with thermal protector
- Electric cable length 5 m
- Rotary nozzle
- Surface cleaner Ø250 mm



MOD	COD				
		MAX	MAX		NET
		bar	psi	l/h gph	kW Hz V kg
2.0 PE	14986	160	2300	460 122	2,2 50-60 220-240~ 10,3

Accessori standard Standard accessories



46328

46332

46541
(6 m)



46572

46356

41565

46327





DSS Series 3.0 PE

IDROPULTRICI ALTA PRESSIONE
high pressure washers



TRADE SELECTION

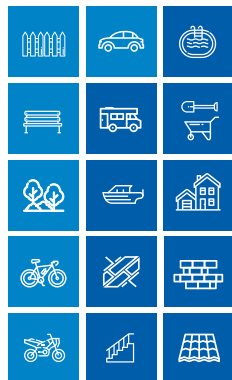

avvolgitubo statico con tubo alta flessibilità 6 m
static hose reel with super flexible hose 6 m



schiumogeno alta pressione
high pressure foam lance



battistrada in gomma
rubber wheels



selettore rotativo a 3 posizioni
off/Eco Speed/Full Speed
3 positions rotative switch
off/Eco Speed/Full Speed



dispositivo click-fast
click-fast connection drive



Caratteristiche Generali

- Manico con avvolgitubo statico
- Pompa a 3 pistoni assiali comandati dal piattello oscillante, testa in alluminio
- Pistoni in acciaio inox temperato
- Valvola di sicurezza automatica con azzeramento della pressione nella testa pompa
- Motore universale a due velocità con protezione termica
- Ugello rotante
- Lava superfici Ø250 mm

General Features

- Two-wheel trolley with handle and static hose reel
- 3 Axial stainless steel pistons wobble-plate pumps
- Tempered stainless steel pistons
- Automatic by-pass valve with pump head pressure discharge
- Dual speed single-phase universal motor with thermal protector
- Rotary nozzle
- Surface cleaner Ø250 mm

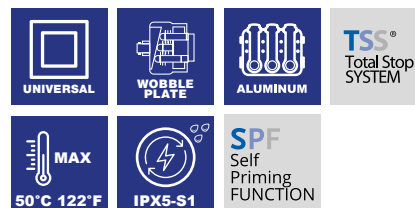

MOD	COD								
		MAX	MAX		NET				
		bar	psi	l/h	gph	kW	Hz	V	kg
3.0 PE	14988	180	2600	500	132	2,5	50-60	220-240~	10,5



Accessori standard Standard accessories



46328

46332
(42 cm)

46541
(6 m)



46572

46356

41565

46540



DUALHYG SYSTEM

DHS è l'innovativo sistema tecnologico brevettato AR.

DHS "2in1 Washer&Sprayer" è l'idropulitrice 2in1.

Due funzioni in un unico prodotto.

In modalità SPRAYING MODE, grazie al serbatoio incorporato, alla pompa a bassa pressione e alla lancia dedicata, si inizia la fase di nebulizzazione che consente azioni di igienizzazione, sanificazione, prelavaggio, disinfestazione e gardening.

Ruotando lo switch su WASHING MODE si passa alla tipica azione di lavaggio.

La pompa altamente performante e la lancia specifica, permettono una comoda e pratica pulizia delle superfici pretrattate e/o la rimozione dello sporco da aree ed oggetti.

DHS is the innovative technological system AR patented.

DHS "2in1 Washer&Sprayer" is the 2in1 High Pressure Washer.

Dual fuction in one product.

By rotating the switch on SPRAYING MODE, thanks to the dedicated lance and tank, it starts the spraying phase of the previously introduced product, which allows to sanitize, pre-washing, gardening and to do pest control.

By rotating the switch on WASHING MODE it starts the cleaning phase.

The powerful pump and its lance, allow to an easy clean of the pre-treated surfaces and/or the dirt removal on objects and areas.

MODALITA' SPRAYING

Sfrutta l'elettropompa a vibrazione monofase per nebulizzare sulle superfici il prodotto precedentemente introdotto nell'apposito serbatoio. Ideale per **sanificare, gardening, pre-lavare e disinfestare.**

SPRAYING MODE:

exploit the electric vibrating single-phase pump for spraying on the surfaces the product previously introduced into the tank. Ideal for sanitizing, gardening, pre-washing and to do pest control.

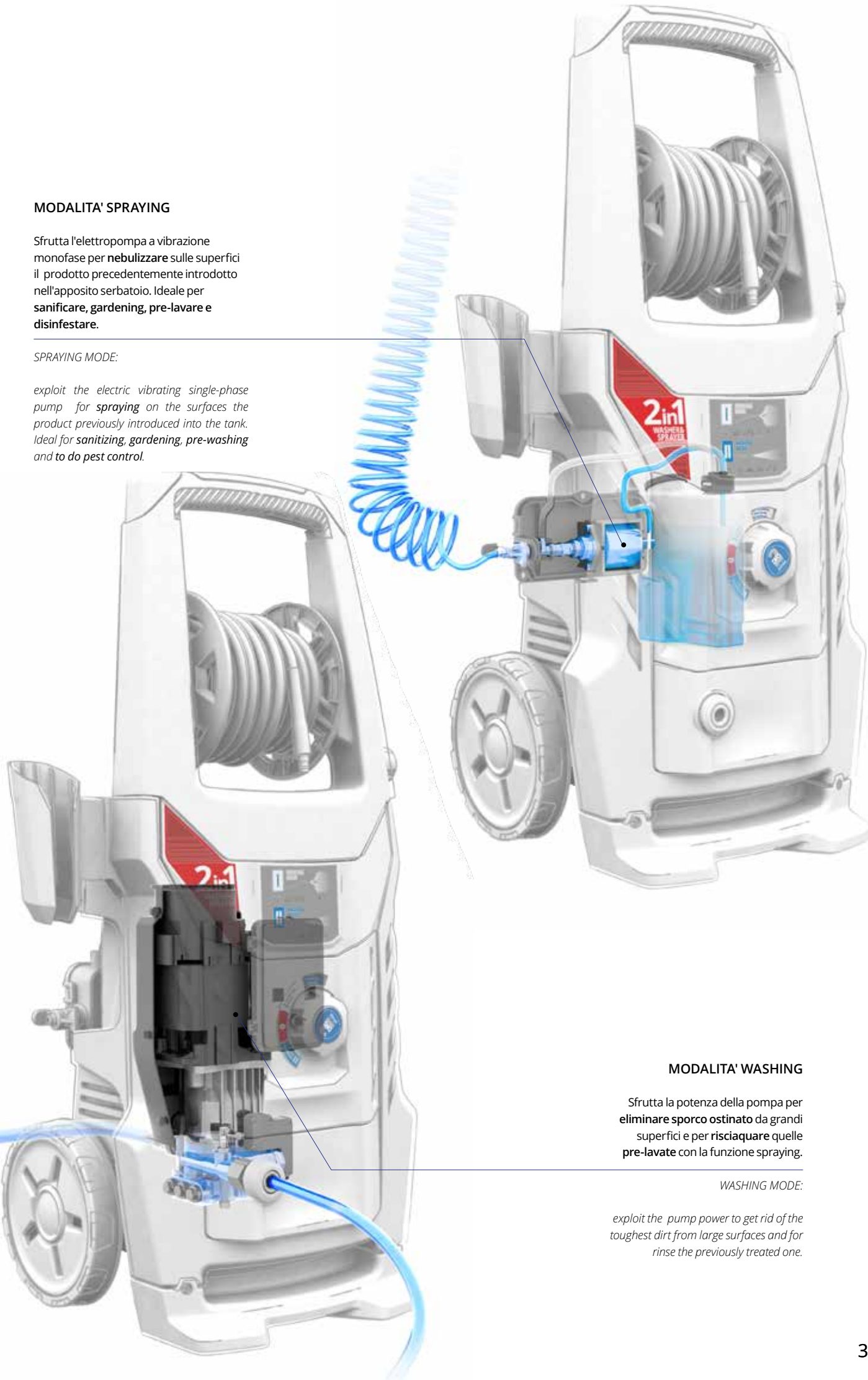

MODALITA' WASHING

Sfrutta la potenza della pompa per **eliminare sporco ostinato** da grandi superfici e per **risciacquare** quelle **pre-lavate** con la funzione spraying.

WASHING MODE:

exploit the pump power to get rid of the toughest dirt from large surfaces and for rinse the previously treated one.

Doppia azione, Doppia efficacia

Dual function, Dual efficiency.



Attivando **I Spraying Mode** si potrà utilizzare la lancia per nebulizzazione prodotti che andranno preventivamente inseriti nel serbatoio. Particolarmente adatta per igienizzare, sanificare, e prelavare superfici e forniture esterne. Ideale per disinfezione zanzare e applicazioni gardening.

*Activate **I Spraying Mode** to sanitize, pre-wash or to do pest control according to the product previously insert into the tank. The perfect model for sanitizing and pre-washing external surfaces and garten furnitures, for doing mosquito control and for garden applications such as spraying.*

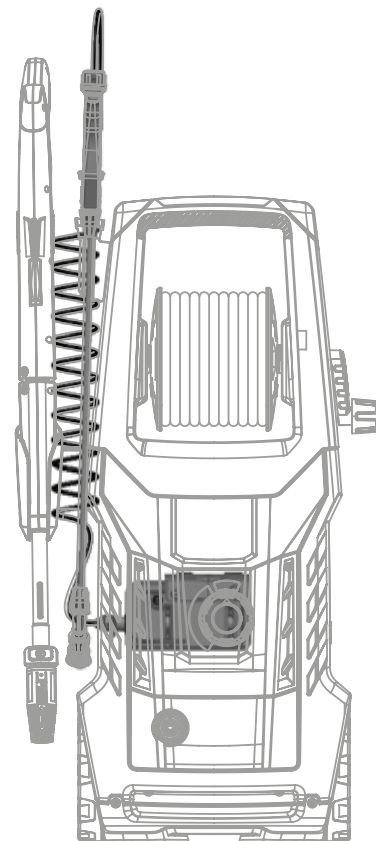

Attivando **II Washing Mode** si potrà utilizzare la lancia per lavare e risciacquare le superfici preventivamente trattate. Adatta per cancellate, muri e pavimentazioni nonchè bici, moto ed automobili.

*Activate **II Washing Mode** to use the lance to wash, clean and rinse the previously treated surfaces. With its powerful motorpump it's suitable to remove dirt from fences, walls, bicycles, motorcycles and cars.*

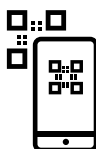
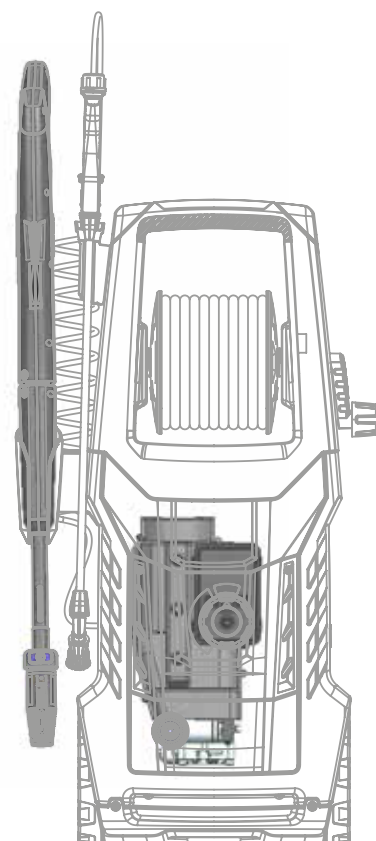

DHS Series 2.A

IDROPULTRICI ALTA PRESSIONE
high pressure washers



lancia per nebulizzazione
con tubo 6 metri
spraying lance with
6 meters hose

avvolgitubo statico con tubo
alta flessibilità 6 m
static hose reel with super
flexible hose 6 m

battistrada in gomma
rubber wheels

selettore rotativo a 3 posizioni
off/spraying mode/washing mode
3 positions rotative switch
off/spraying mode/washing mode

serbatoio integrato
built-in tank

dispositivo click -fast
click-fast connection
drive



Caratteristiche Generali

- Manico con avvolgitubo statico
- Lancia Washing
- Lancia Spraying
- Pompa a 3 pistoni assiali comandati dal piattello oscillante, testa in alluminio
- Pistoni in acciaio inox temperato
- Valvola di sicurezza automatica con azzeramento della pressione nella testa pompa
- Motore universale con protezioni termiche ed elettropompa a vibrazione monofase

General Features

- Two-wheel trolley with handle and static hose reel
- Washing lance
- Spraying lance
- 3 Axial stainless steel pistons wobble-plate pumps
- Tempered stainless steel pistons
- Automatic by-pass valve with pump head pressure discharge
- Universal motor and electric single-phase vibrating pump.



MOD	COD		MAX		MAX					
			bar	psi	l/h	gph	kW	Hz	V	kg
2.A	15153	SPRAYING MODE	4	58	0,3	0,08	0,035	50	220-240~	10,55
		WASHING MODE	160	2320	460	122	2,2	50	220-240~	

Accessori standard Standard accessories



46328 46332 (42 cm) 46541 (6 m)



46844 46845 46846 41565 46327



DUALTECH SYSTEM

DTS è l'innovativo sistema tecnologico brevettato AR che consente di modulare la performance della idropulitrice attraverso l'utilizzo di 2 gruppi pompa-motore. Le prestazioni del sistema sono notevolmente migliori rispetto a quelle ottenute con una tradizionale idropulitrice a pompa singola. A parità di pressione la portata sinergicamente raggiunta da due pompe, attivabile in modalità Fast Cleaning, consente di raggiungere risultati di pulizia eccellenti anche sullo sporco più ostinato risparmiando tempo e fatica. Grazie alla portata aumentata raddoppia anche la distanza raggiunta dal getto - fino a 5 mt - consentendo lavaggi di superfici estese in altezza con una idropulitrice domestica.

DTS is the innovative technological system, AR patented, which gives you the washing power of two motorpumps when you need it. This system achieves notably superior results when compared to those obtained with a single pump pressure washer. The combined flow rate - triggered by the Fast Cleaning mode - enhances washing results, by intensity and extent, reducing the amount of cleaning time required. Thanks to the combined flow rate, DTS doubles the distance that can be reached by the water jet - up to 5 mt - allowing to easily clean even extended vertical surfaces with a domestic pressure washer.

Interruttore di controllo POWER UNIT ergonomico

Permette di scegliere la portata più adatta al lavoro di pulizia: normale o migliorata, grazie alla sinergia di due pompe.

Ergonomic POWER UNIT Switch Control

Allows to choose the most suitable flow rate to fulfill the cleaning task: normal or improved flow, thanks to the double pumps synergy.

POWER UNIT I

Modalità ECO Soft Cleaning:
attiva 1 POWER UNIT per lavaggi leggeri indicati per la pulizia di superfici ridotte evitando inutili sprechi di acqua ed energia

ECO Soft Cleaning Mode:

activate 1 POWER UNIT when the task requires light dirt removal or to wash small surfaces without wasting extra water and energy

POWER UNIT II
Modalità FAST Cleaning:
sfrutta la sinergia di 2 POWER UNITS per eliminare sporco ostinato da grandi superfici o per pulire pareti verticali fino a 5 mt di altezza in breve tempo

*FAST Cleaning Mode:
exploit the synergy of 2 POWER UNITS to get rid of the toughest dirt from large surfaces or to clean walls up to 5 mt height in a short amount of time*



Prestazioni migliori e risparmio di tempo.

Improve performance. Save time.



Attiva **1 POWER UNIT** per un livello di lavaggio leggero particolarmente indicato per la pulizia di biciclette, moto e auto e adatto anche a staccionate, mobili da giardino e tende da sole.

Activate **1 POWER UNIT** when you need to remove light dirt from bicycles, motorcycles, cars or you want fences, outdoor furniture and sun shades to seem like new.

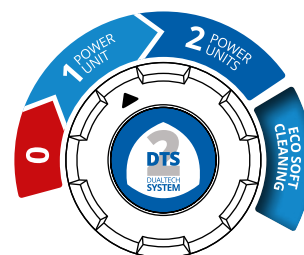

Sfrutta la sinergia di **2 POWER UNITS** insieme quando devi eliminare macchie e sporco ostinato da pavimentazione di pietra o cemento, rivestimenti e muri di mattoni, attrezzature da costruzione.

Exploit the synergy of **2 POWER UNITS** together when you need to get rid of the toughest dirt and stains from stone and cement flooring, brick walls and sidings, roofs or construction applications.

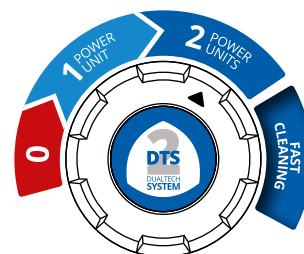

Maggiore portata per una maggiore potenza prestazionale.

Stronger flow rate for a stronger washing power performance.



Getto doppio, tempi dimezzati con l'esclusivo accessorio Twin Nozzle.

Double water jet, halved cleaning time with Twin Nozzle.

Twin Flow si presenta equipaggiata con l'imperdibile accessorio, incluso nella confezione, utile per incrementare la performance di pulizia di grandi superfici risparmiando tempo e fatica. È particolarmente indicato per il lavaggio di muri in cemento o mattoni, pavimentazioni e piscine.

Twin Flow features the ultimate must-have lance accessory, included inside the packaging, that will boost wide surfaces cleaning performance, saving your time and effort. It is perfect to wash concrete or brick walls, floorings, pools in a very efficient way.

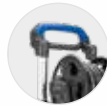

manico telescopico con avvolgitubo statico
telescopic handle with static hose reel

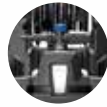

schiumogeno alta pressione
high pressure foam lance



porta accessori integrato
built-in accessory holders

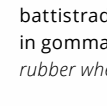

battistrada in gomma
rubber wheels



tubo alta flessibilità 8m
super flexible hose 8m



selettore rotativo a 3 posizioni
off/Eco Soft Cleaning/Fast Cleaning
3 positions rotative switch
off/Eco Soft Cleaning/Fast Cleaning



filtro ingresso acqua ispezionabile
inspectable water intake filter



Caratteristiche Generali

- Manico telescopico con avvolgitubo statico
- 2 Pompe a 3 pistoni assiali comandati dal piattello oscillante, testa in alluminio
- Pistoni in acciaio inox temperato
- Valvola di sicurezza automatica con azzeramento della pressione nella testa pompa
- Doppio motore universale con protezione termica
- Lunghezza cavo elettrico 5m
- Sistema twin nozzle con doppio ugello rotante

General Features

- Two-wheel trolley with telescopic handle and static hose reel
- Two 3 Axial stainless steel pistons wobble-plate pumps
- Tempered stainless steel pistons
- Automatic by-pass valve with pump head pressure discharge
- Twin single-phase universal motor with thermal protector
- Electric cable length 5m
- Twin nozzle system with double rotary nozzle



MOD	COD	MAX		MAX					KG NET
		bar	psi	l/h	gph	kW	Hz	V	kg
4.0	14792	150	2200	810	214	2,5	50-60	220-230~	14



Accessori standard Standard accessories



46328

46332
(42 cm)

46337



46335
(8 m)

46329
(x2)

46330

46344



DTS Series 5.0 TWIN FLOW

IDROPULTRICI ALTA PRESSIONE
high pressure washer



TRADE SELECTION

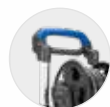
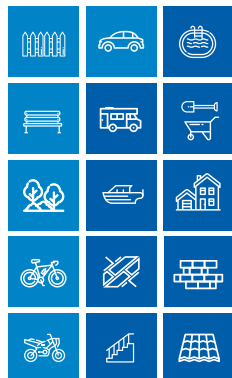

manico telescopico
telescopic handle

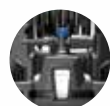

schiumogeno
alta pressione
high pressure
foam lance



porta accessori
integrato
built-in
accessory holders

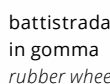

battistrada
in gomma
rubber wheels



avvolgitubo in pressione con tubo
alta flessibilità 8m
in-pressure hose reel with super flexible
hose 8m



selettore rotativo a 3 posizioni
off/Eco Soft Cleaning/Fast Cleaning
3 positions rotative switch
off/Eco Soft Cleaning/Fast Cleaning



filtro ingresso acqua
ispezionabile
inspectable water intake filter

DTS
DUALTECH
SYSTEM

+50%
WPP

Up to
5mt

+70%
FASTER

H.P.
Foam Lance

**Blue Clean
Factor**

Caratteristiche Generali

- Manico telescopico con avvolgitubo in pressione
- 2 Pompe a 3 pistoni assiali comandati dal piattello oscillante, testa in alluminio
- Pistoni in acciaio inox temperato
- Valvola di sicurezza automatica con azzeramento della pressione nella testa pompa
- Doppio motore universale con protezione termica
- Lunghezza cavo elettrico 5m
- Sistema twin nozzle con doppio ugello rotante
- Ugello multi funzione 5 in 1

General Features

- Two-wheel trolley with telescopic handle and in-pressure hose reel
- Two 3 Axial stainless steel pistons wobble-plate pumps
- Tempered stainless steel pistons
- Automatic by-pass valve with pump head pressure discharge
- Twin single-phase universal motor with thermal protector
- Electric cable length 5m
- Twin nozzle system with double rotary nozzle
- Multifunction 5 in 1 nozzle



MOD	COD	MAX	MAX						
		bar	psi	l/h	gph	kW	Hz	V	kg
5.0	14793	160	2300	850	225	2,7	50-60	220-230~	14,6



Accessori standard Standard accessories



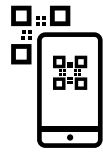

DTS SERIES

Wi-touch

SYSTEM



WI-TOUCH SYSTEM è l'ultima innovazione di casa ANNOVI REVERBERI: un sistema di controllo a distanza per idropultrici progettato e brevettato AR che consente, in abbinamento con i modelli dotati di DTS a doppia pompa, di modulare le performance dell'idropultrice direttamente dalla pistola. Il cambio di modalità di lavoro avviene tramite l'utilizzo del POWER CHANGE, un pratico tasto integrato nella pistola che premuto comunica a distanza all'idropultrice il passaggio dalla modalità ECO SOFT CLEANING a quella FAST CLEANING e viceversa in base all'esigenza.

WI-TOUCH SYSTEM is the latest innovative remote control system for high pressure washers designed and patented by ANNOVI REVERBERI which, combined with the DTS technological system, allows the control of the performance directly from the spray gun. The high pressure washer's status change happens through the POWER CHANGE which is a handy button integrated into the gun. Once pressed it communicates to the high pressure washer to switch mode from ECO SOFT CLEANING to FAST CLEANING and vice versa any time it is needed according to the cleaning needs.





Wi-touch
MODE ON



POWER CHANGE

Attivazione Wi-TOUCH

Wi-TOUCH MODE ACTIVATION

WI-TOUCH SYSTEM è l'innovativo sistema di controllo a distanza per idropultrici progettato e brevettato Annovi Reverberi che consente, abbinato al sistema tecnologico DTS, di modulare le performance dell'idropulitrice direttamente dalla pistola attraverso il "power change".

WI-TOUCH SYSTEM is the innovative remote control system for high pressure washers designed and patented by Annovi Reverberi which, combined with the DTS technological system, allows the performance of the pressure washer to be modulated directly from the gun through the "power change".



Per attivare la modalità WI-TOUCH è sufficiente impostare il selettore di controllo sulla posizione 1.

Premendo in seguito la leva cambio modalità si controlla il passaggio tra modalità eco soft claning e fast cleaning e viceversa, in base alle proprie necessità.

To activate the WI-TOUCH mode, simply set the control selector to position 1.

Then, by pressing the power change lever, you can switch between eco soft cleaning and fast cleaning modes and vice versa, according to your needs.

power change LED indicator
indicatore LED di cambio modalità



power change trigger
leva cambio modalità



La modalità **ECO CLEANING** attiva un lavaggio leggero che permette di evitare inutili sprechi di acqua ed energia, particolarmente indicato per pulire veicoli, staccionate, mobili da giardino, tende da sole e superfici delicate.

La modalità **FAST CLEANING** offre un miglioramento delle performance del 50% grazie all'incremento della intensità e dell'ampiezza del getto pulente offrendo una pulizia eccellente anche sullo sporco più ostinato. Consigliata per lavare velocemente le superfici più estese, per pulire in altezza e per eliminare macchie e sporco profondo da pavimentazioni di pietra o cemento, rivestimenti e muri di mattoni, attrezzature da costruzione.

The ECO CLEANING mode activates a light wash that allows you to avoid unnecessary waste of water and energy, particularly suitable for cleaning vehicles, fences, garden furniture, awnings and delicate surfaces.

The FAST CLEANING mode offers a 50% performance improvement thanks to an increase in the intensity and width of the cleaning jet, offering excellent cleaning even on the most stubborn dirt. Recommended for quickly washing larger surfaces, for cleaning at height and for removing stains and deep dirt from stone or concrete floors, brick claddings and walls, construction equipment.



DTS Series 4.1 Wi-TOUCH

IDROPULTRICI ALTA PRESSIONE
high pressure washers

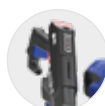
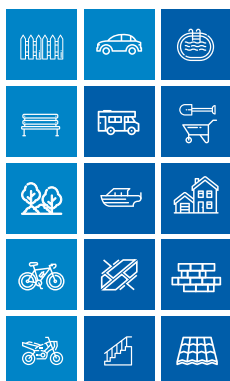

pistola Wi-TOUCH con prolunga
Wi-TOUCH trigger gun with gun extension



schiumogeno alta pressione
high pressure foam lance



porta accessori integrato
built-in accessory holders



Twin Nozzle



manico telescopico con ganci per appoggio pistola
telescopic handle with gun parking hooks



tubo alta flessibilità 8m
super flexible hose 8m



selettore ergonomico di controllo Wi-TOUCH mode
ergonomic Wi-TOUCH mode control switch



filtro ingresso acqua ispezionabile
inspectable water intake filter



Caratteristiche Generali

- Pistola Wi-TOUCH con controllo remoto
- Manico telescopico con avvolgitubo statico per tubo AP
- 2 pompe a 3 pistoni assiali comandati dal piattello oscillante, testa in alluminio
- Pistoni in acciaio inox temperato
- Valvola di sicurezza automatica che diminuisce la pressione residua, agevola l'azionamento della leva pistola e riduce l'affaticamento della mano
- Doppio motore universale con protezione termica
- Lunghezza cavo elettrico 5m
- Sistema twin nozzle con doppio ugello rotante

General Features

- Wi-TOUCH trigger gun with remote control
- Two-wheel trolley with telescopic handle and static hose reel
- Two 3 axial stainless steel pistons wobble-plate pumps
- Tempered stainless steel pistons
- Automatic safety valve that decreases the residual pressure, facilitates the operation of the gun lever and reduces hand fatigue
- Twin single-phase universal motor with thermal protector
- Electric cable length 5m
- Twin nozzle system with double rotary nozzle

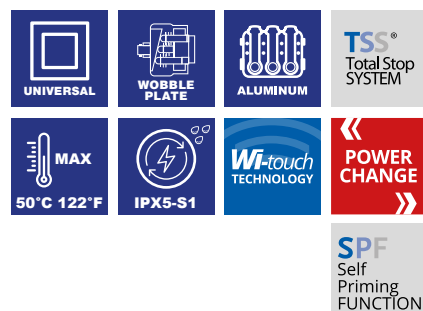

MOD	COD	MAX	MAX							KG NET
		bar	psi	l/h	gph	kW	rpm	Hz	V	kg
4.1	15180	150	2175	810	214	2,5	3400	50	220-240~	14,7



Accessori standard Standard accessories



DPS SERIES DUALPOWER SYSTEM

DUAL POWER SYSTEM è l'innovativo sistema tecnologico che consente di modulare la performance della idropulitrice attraverso l'utilizzo di una comoda e semplice regolazione integrata sulla pistola.

Ruotando il regolatore verso la modalità HARD si utilizza progressivamente tutta la potenza dell'idropulitrice per affrontare i lavori più gravosi e impegnativi; ruotando verso la modalità SOFT si riduce la potenza del getto in modo da garantire un lavaggio più delicato delle superfici.

DUAL POWER SYSTEM is the innovative technological system that allows you to modulate the high pressure washer's performance using a comfortable and easy regulation feature integrated in the trigger gun.

By rotating the regulator to HARD, you progressively use all the high pressure washer's power for dealing with the toughest cleaning jobs. By turning the regulator to SOFT you decrease the pressure to guarantee a more delicate washing effect on the surfaces.



PERFORM & CONTROL



DPS è l'innovativo sistema tecnologico che consente di modulare la performance della idropulitrice attraverso l'utilizzo di una comoda e semplice regolazione integrata sulla pistola.

Ruotando il regolatore verso la modalità HARD si utilizza progressivamente tutta la potenza dell'idropulitrice per affrontare i lavori più gravosi e impegnativi; ruotando verso la modalità SOFT si riduce la potenza del getto in modo da garantire un lavaggio più delicato delle superfici.

Seleziona HARD quando devi eliminare macchie e sporco ostinato da pavimentazione di pietra o cemento, rivestimenti e muri di mattoni, attrezzature da costruzione ed automezzi.

Seleziona SOFT per un livello di lavaggio leggero particolarmente indicato per la pulizia di biciclette, moto e auto e adatto anche a staccionate, mobili da

ble.



DPS is an innovative technological system that allows you to vary the high pressure washer's performance using a comfortable and easy regulation feature integrated in the trigger gun.

By moving the regulation to HARD, you progressively use all the high pressure washer's power for dealing with the toughest cleaning jobs. By setting the regulation to SOFT you decrease the pressure to guarantee a more delicate washing effect. Select HARD for removing tough dirt from paving stones or cement surfaces, wall cladding and brick walls, construction equipment and muddy vans and vehicles. Select SOFT for more delicate cleaning effect, such as cleaning bicycles, cars and motorbikes, garden fencing, garden furniture and sun shades.

HARD

SOFT

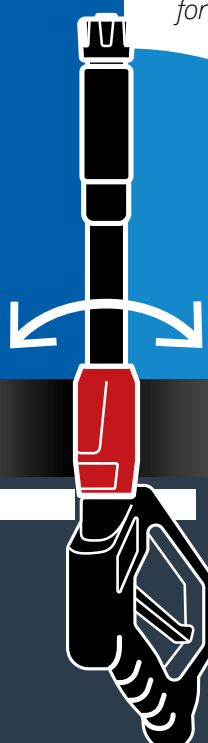

DPS Series 7.0 DUAL POWER

IDROPULTRICI ALTA PRESSIONE
high pressure washers

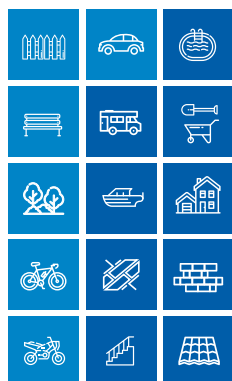

pistola con regolatore di pressione
trigger gun with pressure regulator

schiumogeno alta pressione
high pressure foam lance

lancia in metallo con attacco rapido
metal lance with quick connection

doppio ugello rotante PRO
twin rotary nozzle PRO

manico telescopico con ganci per appoggio pistola
telescopic handle with gun parking hooks

avvolgitubo in pressione con tubo 10 m
In-pressure hose reel with hose 10 m

porta-accessori integrato built-in accessory holders

filtro ingresso acqua ispezionabile e manometro
inspectable water intake filter and pressure gauge



Caratteristiche Generali

- Pistola con regolatore di pressione
- Carrello a due ruote completo di manico ed avvolgitubo
- Pompa a 3 pistoni assiali comandati dal piattello oscillante
- Pistoni in acciaio inox temperato
- Valvola di sicurezza automatica con azzeramento della pressione nella testa pompa
- Manometro
- Motore elettrico monofase a induzione con protezione termica
- Lunghezza cavo elettrico 5 m
- Doppio ugello rotante PRO
- Tubo rinforzato con treccia in acciaio (10 m)

General Features

- Trigger gun with pressure regulator
- Two-wheel trolley with handle and hose reel
- 3 Axial stainless steel pistons wobble-plate pump
- Tempered stainless steel pistons
- Automatic by-pass valve with pump head pressure discharge
- Pressure gauge
- Single-phase induction motor with thermal protector
- Electric cable length 5 m
- Twin Nozzle PRO
- Steel braided hose (10 m)

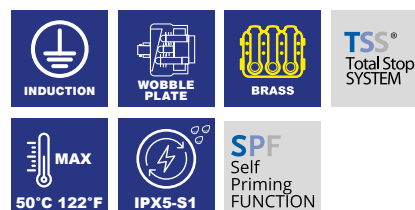

MOD	COD	MAX		MAX						KG NET
		bar	psi	l/h	gph	kW	rpm	Hz	V	kg
7.0	15343	160	2300	700	185	2,8	2800	50	220-230~	26,2



Accessori standard Standard accessories



BATTERY WATER CLEANER

Battery Water Cleaner è l'innovativa idropistola a batteria indipendente dalla rete idrica. Grazie alla funzione autoadescante integrata, è in grado di aspirare l'acqua da qualsiasi recipiente, come cisterne o secchi ma è anche possibile collegarsi all'impianto idrico dove presente.

Dotata del sistema DSS, dual speed system, è possibile regolare la velocità tra eco speed e max speed ogni volta necessario.

Versatile, compatta e facile da trasportare è ideale per l'utilizzo nelle più svariate situazioni outdoor.

Battery Water Cleaner is the innovative battery pressure washer independent from the water supply that allows to draw water from any bowl such as buckets or tanks. it's also possible to connect the battery water cleaner to the main water system when available.

Thanks to the DSS integrated system it's possible to modulate the performanc between eco mode and speed mode anytime you want according to the surface that has to be cleaned.

Versatile, portable and compact it's the perfect solutions for outdoor situations and more.



BATTERY WATER CLEANER

Idropistola portatile a batteria dotata del sistema tecnologico DSS Annovi Reverberi che consente di modulare le performance passando dalla modalità ECO SPEED e quella MAX SPEED in base all'esigenza di lavaggio, premendo l'apposito pulsante. Portatile, compatta, versatile e indipendente da rete idrica ed elettrica. Ideale per molteplici situazioni nell'esterno casa e outdoor living.

The Battery Water Cleaner is equipped with the DSS technological system by Annovi Reverberi that allows to modulate the performance choosing among the ECO SPEED mode and the MAX SPEED mode through the appropriate button any time needed according to the surface. Independent of the water supply, portable, compact and versatile. Perfect for many outdoor situations and more.

Batteria al litio ricaricabile da 18V inclusa.

18V Rechargeable lithium battery included.



ECO SPEED

50% ENERGY SAVING



MAX SPEED

FULL PERFORMANCE



18V

**0°/ 20°/ 60° +
ROTARY JET NOZZLE**

Quattro funzionalità
in un unico accessorio.
*One nozzle,
multiple uses.*



**4in1
NOZZLE**

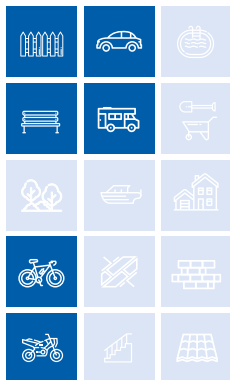

Caratteristiche Generali

- Idropistola a batteria (18V)
- Batteria ricaricabile al litio
- Sistema tecnologico DSS integrato
- Selettore modalità ECO/MAX SPEED
- Motopompa anti-vibrazione e silenziosa
- Kit schiumogeno
- Kit autoadescamento (4 m)

General Features

- Battery Water Cleaner
- Rechargeable lithium battery
- Double Speed System
- ECO/MAX SPEED selector
- Super Silent anti-vibration motor-pump
- Foam lance bottle
- Self-priming kit (4 m)

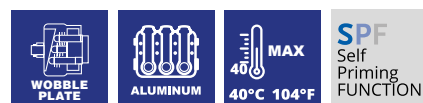

MOD	COD	DSS	MAX	MAX							
			bar	psi	l/h	gph	V	Ah	battery run time	motor type	kg
BC250 DSS	15389	MAX SPEED	24	350	175	46.2	18	2,5	11 min*	DC 250 W	1,8

* 21 min. ECO SPEED MODE

Accessori standard Standard accessories







ACCESSORI & DETERGENTI

Accessories & detergents





CARATTERISTICHE GENERALI

Innovativo e pratico accessorio multifunzione per idropulitrici ad alta pressione che permette, grazie ad un semplice click, il passaggio dall'azione di lavaggio (**modalità CLEAN**) a quella di risciacquo e asportazione (**modalità SWEEP**). Grazie ai 3 ugelli, la **superficie pulente aumenta del 30%** consentendo un risparmio di tempo e di energia.

GENERAL FEATURES

*Innovative and practical multifunctional accessory for high pressure washers which allows, thanks to a simple click, the switch from the washing action (**CLEAN mode**) to the rinsing and sweeping action (**SWEEP mode**). Thanks to the 3 nozzles, **the cleaning surface increases by 30%**, saving time and energy.*

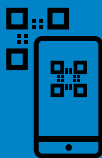

NEW

serbatoio detergente trasparente con regolazione dosaggio*
*transparent detergent tank with dosage adjustment**

leva cambio posizione
position change lever



3 ugelli
3 nozzles

ruote
wheels

setole ad alta efficacia pulente
highly effective cleaning bristles

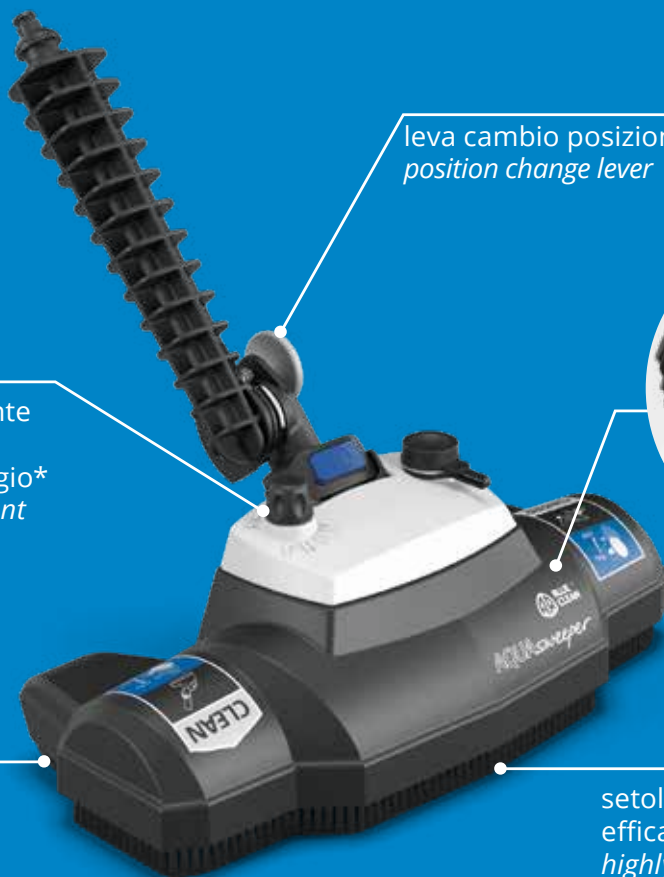

APPLICAZIONI - APPLICATIONS



pavimenti
flooring,
paving
stones



scale
stairs



casa
house



piscine
pools

CLEAN MODE

Nella modalità **CLEAN** l'azione meccanica combinata del getto ad alta pressione a tre ugelli e delle setole consente la rimozione e l'asportazione di ogni tipo di sporco dalla superficie trattata.

The CLEAN mode combines the mechanical action of three-nozzle high pressure jet with the bristles, allowing you to remove any type of dirt from treated surfaces

1

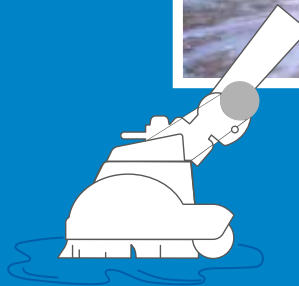

2

SWEEP MODE

Grazie alla sua posizione ergonomica la modalità **SWEEP** consente di allontanare lo sporco rimosso e i residui di detergente lasciando la superficie perfettamente pulita.

Thanks to its ergonomic position, the SWEEP mode allows you to remove the dirt previously detached and detergent residues, leaving the surface perfectly cleaned.

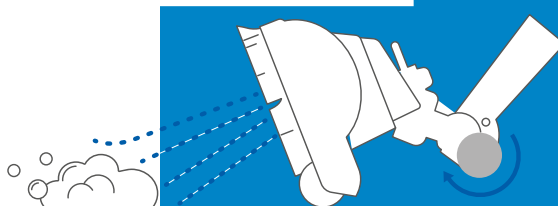

+30% di superficie pulita*
of cleaned area*



*rispetto ad un normale patio cleaner
*compared to a normal patio cleaner



Detergenti. *Detergent*



AUTO&BARCHE *cars and boats*

Detergente pronto all'uso.
Ideale per parabrezza e superfici metalliche delicate.
Rimuove lo sporco oleoso senza lasciare aloni.
Piacevole fragranza alla mente piperita.
Formulazione esente da EDTA e NTA e conservanti privi di formaldeide ed alogeni.

*Ready-to-use cleaner.
Ideal for windscreens and delicate metal surfaces. Removes oily dirt without leaving smears.
Pleasant peppermint scent.
Formula free from EDTA and NTA and preservatives without formaldehyde or halogens.*

Cod. 41872



PANNELLI SOLARI *solar panels*

Detergente pronto all'uso.
Ideale per la pulizia di pannelli solari ed impianti fotovoltaici.
Piacevole fragranza di lavanda.
Formulazione esente da EDTA e NTA e conservanti privi di formaldeide ed alogeni.

*Ready-to-use cleaner.
Ideal for cleaning solar panels and photovoltaic systems.
Pleasant lavender scent.
Formula free from EDTA and NTA and preservatives without formaldehyde or halogens.*

Cod. 43485



BICI&MOTO *bicycle and motorbikes*

Detergente pronto all'uso.
Ideale per la pulizia di superfici delicate quali la vernice di telai di bici e moto.
Rimuove alla perfezione tracce di fango ed olio.
Piacevole fragranza di bouquet fiorito.
Formulazione esente da EDTA e NTA e conservanti privi di formaldeide ed alogeni.

*Ready-to-use cleaner.
Ideal for cleaning delicate surfaces such as the paintwork of bike and motorbike frames. Removes mud and oil residues to perfection.
Pleasant floral scent.
Formula free from EDTA and NTA and preservatives without formaldehyde or halogens.*

Cod. 41871



ERBA SINTETICA *synthetic grass*

Detergente pronto all'uso.
Ideale per pulire superfici in erba sintetica. Rimuove lo sporco che si annida alla base senza danneggiarne la consistenza e la forma.
Piacevole fragranza di pino selvatico.
Formulazione esente da EDTA e NTA e conservanti privi di formaldeide ed alogeni.

*Ready-to-use cleaner.
Ideal for cleaning artificial turf surfaces. Removes the dirt that builds up at the base without damaging the turf's consistency or shape.
Pleasant wild pine scent.
Formula free from EDTA and NTA and preservatives without formaldehyde or halogens.*

Cod. 43484



DECKING *wood surfaces*

Detergente pronto all'uso.
Pulisce senza danneggiare tutte le pavimentazioni in decking e legno, sia trattato che naturale.
Piacevole fragranza alla vaniglia.
Formulazione esente da EDTA e NTA e conservanti privi di formaldeide e alogeni.

*Ready-to-use cleaner.
Cleans all treated and untreated decking and wood floors without damaging surfaces.
Pleasant vanilla scent.
Formula free from EDTA and NTA and preservatives without formaldehyde or halogens.*

Cod. 43487



MURI&PIETRE *walls and stones*

Detergente pronto all'uso.
Pulisce le superfici in pietra naturale, in sasso e facciate in muratura, rimuovendo anche lo sporco più ostinato.
Fragranza di sapone di Marsiglia.
Formulazione esente da EDTA e NTA e conservanti privi di formaldeide ed alogeni.

*Ready-to-use cleaner.
Cleans natural and dressed stone surfaces and brickwork facades, removing even the most stubborn dirt.
Savon de Marseille scent.
Formula free from EDTA and NTA and preservatives without formaldehyde or halogens.*

Cod. 43486





TENDE DA SOLE *awnings*

Detergente pronto all'uso. Ideale per la pulizia di teli in tessuto e plastica. Rimuove con facilità lo sporco che si accumula sulle strutture all'aperto. Piacevole fragranza agli agrumi. Formulazione esente da EDTA e NTA e conservanti privi di formaldeide ed alogeni.

Ready-to-use cleaner. Ideal for cleaning fabric and plastic blinds. Easily removes the dirt that builds up on outdoor structures. Pleasant citrus scent. Formula free from EDTA and NTA and preservatives without formaldehyde or halogens.



VETRI *glass*

Detergente pronto all'uso. Ideale per la pulizia di superfici in vetro, trasparenti o riflettenti. Rimuove lo sporco senza lasciare aloni e striature. Delicata fragranza fresco di pulito. Formulazione esente da EDTA e NTA e conservanti privi di formaldeide ed alogeni.

Ready-to-use cleaner. Ideal for cleaning clear or reflecting glass surfaces. Removes dirt without leaving smears or streaks. Delicate, clean scent. Formula free from EDTA and NTA and preservatives without formaldehyde or halogens.



UNIVERSALE *universal*

Detergente pronto all'uso. Rimuove facilmente lo sporco accumulato sulle strutture outdoor in plastica, ceramica e metallo. Delicata fragranza di pesca. Formulazione esente da EDTA e NTA e conservanti privi di formaldeide ed alogeni.

Ready-to-use cleaner. Easily removes the dirt that builds up on outdoor plastic, ceramic and metal structures. Delicate peach scent. Formula free from EDTA and NTA and preservatives without formaldehyde or halogens.

Cod. 43483 11e 

Cod. 43488 11e 

Cod. 41870 (1l) 11e 
 Cod. 43491(5l) 51e



HYG

Detergente igienizzante pronto all'uso per la sanificazione dell'esterno casa. Utilizzato in combinazione con la tua idropulitrice ad alta pressione aiuta a ridurre la carica batterica. HYG lascia una gradevole sensazione di pulito e freschezza grazie al suo profumo di limone.

AGISCE IN MODO MECCANICO CON L'ASPORTAZIONE DELLO SPORCO

Ready-to-use sanitizing detergent for external home surfaces and furnitures. Use it with your high pressure washer to reduce the bacterial count. HYG gives a nice cleaning lemon scent. It works mechanically with dirt removal.





































Cod. 46705 (1l) 11e
 Cod. 46706 (5l) 51e
 Cod. 46707 (12l) 121e



1.3.4.5 Series

ACCESSORI accessories



		1 Series	143	3 Series	397	4 Series	491	5 Series	589	591	2.0 PE	3.0 PE	2.A	4.0 TF	5.0 TF	4.1	7.0	BC250	
Lancia multifunzione Multifunction lance		46349 (48 cm)	○	○															
		46352 (48 cm)			○			○		○									
		46545 (48 cm)			○						○								
Kit pulizia tubazioni Pipe drain kit		43827 (8 m)	○	○	○						○	○	○						
		41588 (10 m)	○	○	○	○	○	○	○	○	○	○	○	○	○	○	○	○	○
		41693 (16 m)	○	○	○	○	○	○	○	○	○	○	○	○	○	○	○	○	○
		46364 (8 m)																	○
Spazzola fissa Fixed brush		41577	○	○	○	○	○	○	○	○	○	○	○	○	○	○	○	○	○
Spazzola fissa Fixed brush		46353	○	○	○	○					○	○	○	○	○	○	○	○	○
Spazzola rotante Rotary brush		41578	○	○	○	○	○	○	○	○	○	○	○	○	○	○	○	○	○
Spazzola lavante Power brush		46361	○	○	○	○	○	○	○	○	○				○				
		46362												○	○				
Lavapavimenti d. 25 cm Patio cleaner d. 25 cm		46356	○	○	○	○					S	S	○						
Lavapavimenti d. 30 cm con serbatoio detergente Patio cleaner d. 30 cm with detergent tank		41581	○	○	○	○					○	○							
Lavapavimenti d. 30 cm Patio cleaner d. 30 cm		46358	○	○	○	○					○	○							
		46359					○	○											○
Aquasweeper Aquasweeper		46686	○	○	○	○					○	○	○	○	○	○	○	○	○
Kit lancia sabbiane Sandblasting lance kit		41760 (50 cm)	○	○	○	○					○	○							
		47108 (50 cm)												○	○	○			
Kit lancia sabbiane PRO Sandblasting lance kit PRO		41591 (50 cm)				○													
		41762 (50 cm)						○	○										○
Sabbia calibrata e filtrata Calibrated, filtered sand		3207 (5 Kg)	○	○	○	○	○	○	○	○	○	○	○	○	○	○	○	○	○
		41770 (25 Kg)	○	○	○	○	○	○	○	○	○	○	○	○	○	○	○	○	○
Kit aspirazione acqua Water suction kit		41592	○	○	○	○	○	○	○	○	○	○	○	○	○	○	○	○	○
Kit adescamento selfpriming kit		47332	○	○	○	○	○	○	○	○	○	○	○	○	○	○	○	○	○
Adattatore snodato per testine Adjustable head nozzle adaptor		46009	○	○	○	○					○	○	○	○	○				
Kit lancia sottococca Underbody lance kit		46354					○	○	○										
		46372																	○
Kit estensione lancia 1,6 m Extension lance kit 1,6 m		46355	○	○	○	○													○
Kit adattatori Adaptors kit		41758	○	○	○	○	○	○	○	○	○	○	○	○	○	○	○	○	○
Kit adattatori accessori Accessories adaptors kit		41890*	○	○	○	○					○	○	○	○	○	○	○	○	○
Kit filtro acqua Water filter kit		41593	○	○	○	○	○	○	○	○	○	○	○	○	○	○	○	○	○
Kit attacco rapido Click fast kit		41580	○	○	○	○	○	○	○	○	○	○	○	○	○	○	○	○	○
Filtro acqua ispezionabile Inspectable water filter		41663 (3 pcs)	S	S	S	S	S	S	S	S	S	S	S	S	S	S	S	S	S
Disconnettore idrico Water cut-off kit		46949	○	○	○	○	○	○	○	○	○	○	○	○	○	○	○	○	○
Prolunga lancia Lance extension		5120011																	S
Testina quattro in uno Four in One nozzle		5120040																	S
Kit schiumogeno Foam lance bottle		5120031																	S
Kit autoadescamento Self-priming kit		5120051																	S
Batteria al litio Lithium battery		5120071																	S
Caricabatterie rapido Fast battery charger		5120190																	S

(*) Adattatori universali da collegarsi ad accessori con attacco a baionetta AR Blue Clean, compatibili con idropulitrici ad alta pressione aventi analoghe prestazioni di quelle indicate in tabella

(*) Universal adaptors to be connected to Blue Clean accessories with bayonet fitting, suitable for pressure washers with similar specifications of the models listed in the chart

**LINEA
PROFES-
SIONAL**

Professional line

PRO COLD



Prodotti tecnicamente pensati per resistere ad utilizzi gravosi e continuativi. Una gamma completa per soddisfare le diverse esigenze lavorative di professionisti che ricercano ogni giorno qualità, prestazioni affidabili e velocità d'utilizzo. In due parole la qualità Annovi Reverberi. È questo il denominatore comune della gamma PRO COLD – idropulitrici ad acqua fredda costruite con pompe ad elevate prestazioni per garantire alla macchina una extra durata anche in condizioni di utilizzo gravose ed estreme. Ideali per il settore Automotive e per cantieri edili.

Products engineered to withstand continual heavy-duty use. A complete range to meet the various working needs of professionals who need quality, reliable performance and fast operation, day in, day out. In other words, Annovi Reverberi quality. This is the common denominator of the PRO COLD range – cold water high pressure washers built with high-performance pumps to guarantee an exceptionally long lifetime even in extreme, heavy-duty conditions. Ideal for the automotive industry and construction sites.

Applicazioni ed indicatori di prestazioni PRO COLD

PRO COLD performance
Indicators & Applications
BLUE CLEAN PRO LEVEL

○ LIGHTPRO

Fascia di idropultrici progettate per utilizzatori esperti che hanno necessità di eseguire lavori di pulizia abbastanza frequenti e che richiedono una abbondante riserva di potenza.

High pressure washer category designed for skilled users tackling cleaning quite frequent jobs operations which need plenty of power in reserve.

● HEAVYPRO

Fascia di idropultrici progettate per professionisti che hanno necessità di eseguire lavori di pulizia molto frequenti che richiedono le massime prestazioni.

High pressure cleaner category designed for professionals, dealing with cleaning high frequent jobs that need the very highest-performing appliances.

BLUE CLEAN FACTOR



La combinazione ideale tra prestazioni tecniche e configurazione commerciale per poter risolvere al meglio le tue esigenze di pulizia. I prodotti che hanno il BLUE FACTOR sono i migliori, all'interno della loro categoria, per poter pulente, facilità d'utilizzo e prestazioni tecniche. Il mix perfetto per ogni tua esigenza di pulizia.

The ideal combination of technical features and commercial configuration, to deliver the best solution to your cleaning needs. Products with the BLUE FACTOR are best-in-class in cleaning power, ease of use and technical performances. The perfect mix for all your cleaning requirements.





Applicazioni PRO COLD

PRO COLD
Applications

PROFESSIONAL APPLICATIONS

Annovi Reverberi ha realizzato una gamma di prodotti, ideale per gli artigiani più esigenti, che ben si coniuga alle loro esigenze professionali. Estremamente versatili i prodotti della linea PRO rispondono perfettamente alle necessità lavorative di artigiani idraulici, carrozzieri, muratori; un costante supporto a ciascuna professione che consente risparmio tempo ma soprattutto fatica. Utilizzo intuitivo, accessori professionali e manovrabilità estrema rendono i prodotti ARBC la miglior scelta per la categoria.

Annovi Reverberi has produced a range of products ideal for the most demanding craftsmen, carefully tailored to their professional requirements. Extremely versatile, the PRO line products are the perfect fit for the working needs of plumbers, car body repair workshops and builders; constant support for each trade, saving time and above all effort. User-friendliness, professional accessories and extremely easy handling make ARBC products the right choice for this category.



edilizia
construction



**agricoltura
zootecnica**
agriculture
zootechny



artigianato
crafts



car wash



automotive



6 Series

611		<input checked="" type="checkbox"/>	<input checked="" type="checkbox"/>	<input checked="" type="checkbox"/>	<input type="checkbox"/>	<input type="checkbox"/>
613		<input checked="" type="checkbox"/>	<input checked="" type="checkbox"/>	<input checked="" type="checkbox"/>	<input type="checkbox"/>	<input type="checkbox"/>
614		<input checked="" type="checkbox"/>	<input checked="" type="checkbox"/>	<input checked="" type="checkbox"/>	<input type="checkbox"/>	<input type="checkbox"/>
613K		<input checked="" type="checkbox"/>	<input checked="" type="checkbox"/>	<input checked="" type="checkbox"/>	<input type="checkbox"/>	<input type="checkbox"/>
614K		<input checked="" type="checkbox"/>	<input checked="" type="checkbox"/>	<input checked="" type="checkbox"/>	<input type="checkbox"/>	<input type="checkbox"/>
630		<input checked="" type="checkbox"/>	<input checked="" type="checkbox"/>	<input checked="" type="checkbox"/>	<input type="checkbox"/>	<input type="checkbox"/>
630K		<input checked="" type="checkbox"/>	<input checked="" type="checkbox"/>	<input checked="" type="checkbox"/>	<input type="checkbox"/>	<input type="checkbox"/>
670		<input checked="" type="checkbox"/>	<input checked="" type="checkbox"/>	<input checked="" type="checkbox"/>	<input type="checkbox"/>	<input type="checkbox"/>
671		<input checked="" type="checkbox"/>	<input checked="" type="checkbox"/>	<input checked="" type="checkbox"/>	<input type="checkbox"/>	<input type="checkbox"/>
680		<input checked="" type="checkbox"/>	<input checked="" type="checkbox"/>	<input checked="" type="checkbox"/>	<input type="checkbox"/>	<input type="checkbox"/>
680K		<input checked="" type="checkbox"/>	<input checked="" type="checkbox"/>	<input checked="" type="checkbox"/>	<input type="checkbox"/>	<input type="checkbox"/>

9 Series

930		<input checked="" type="checkbox"/>	<input checked="" type="checkbox"/>	<input checked="" type="checkbox"/>	<input checked="" type="checkbox"/>	<input checked="" type="checkbox"/>
960		<input checked="" type="checkbox"/>	<input checked="" type="checkbox"/>	<input checked="" type="checkbox"/>	<input checked="" type="checkbox"/>	<input checked="" type="checkbox"/>
980		<input checked="" type="checkbox"/>	<input checked="" type="checkbox"/>	<input checked="" type="checkbox"/>	<input checked="" type="checkbox"/>	<input checked="" type="checkbox"/>



10 Series

1003K 1005K		●	●	●	●	
1001		●	●	●		
1003 1003XE		●	●	●	●	
1006XE		●	●	●	●	
1007 1007XE		●	●	●	●	●
1009RLW		●	●	●	●	●
1015		●	●	●	●	●
1018 1018H		●	●	●	●	●

11 Series

1120		●	●	●	●	●
------	--	---	---	---	---	---



14 Series

1415		●	●	●		
1425		●	●	●		
1435		●	●	●		
1440		●	●	●		
1445		●	●	●		
1445XE		●	●	●		
1447		●	●	●	●	
1450		●	●	●	●	
1460		●	●	●	●	●
1475		●	●	●	●	●
1475XE		●	●	●	●	●
1480		●	●	●	●	●
1490		●	●	●	●	●



Pompe

Pumps

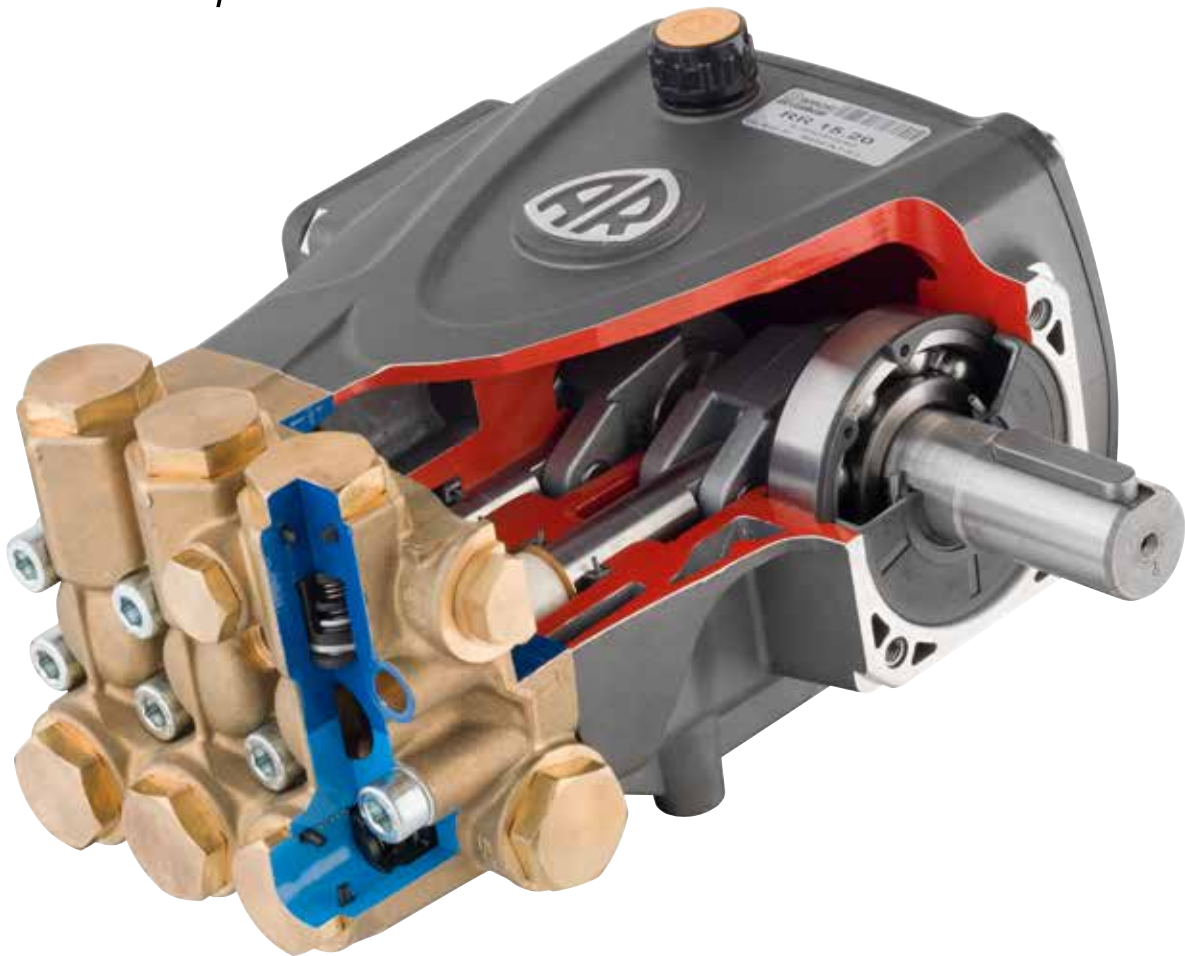

Pompa con sistema biella-manovella per utilizzo in orizzontale. Corpo e coperchi laterali con livello olio.
 Bielle in lega zinco-alluminio pressofuso.
 Testa in ottone forgiato con disegno ad alta resistenza.
 Pistoni in ceramica.
 Sistema di tenuta a doppia guarnizione.
 I componenti interni sono tutti di dimensioni maggiorate in grado di garantire una buona affidabilità e resistenza nel tempo.

*Wobble plate pump for horizontal use.
 Crankcase and side covers with oil level.
 Connecting rods in die-cast zinc-aluminium alloy.
 High strength forged brass head with design.
 Ceramic plungers.
 Double seal sealing system.
 The internal components are all oversized to ensure good reliability and durability.*

HJRS-A

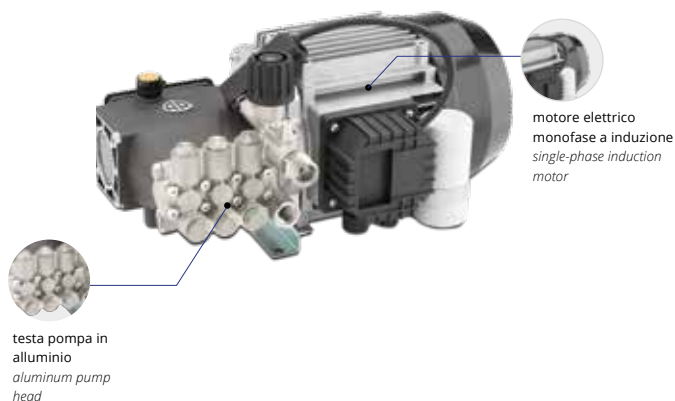

- Pompa a 3 pistoni in ceramica con sistema biella-manovella, testa pompa in alluminio
- Valvola di sicurezza automatica con azzeramento della pressione nella testa pompa
- Motore elettrico monofase a induzione con protezione termica
- Sistema di arresto totale dell'idropulitrice a distanza
- Aspirazione acqua da serbatoio con funzione autoadescente

- *Triplex pump with ceramic pistons and connecting rod system with aluminium pump head*
- *Automatic by-pass valve with pump head pressure discharge*
- *Single-phase induction motor with thermal protection*
- *Remote control for total shut-down of high pressure washer*
- *Inlet water suction from tank by self priming function*



HPV-O

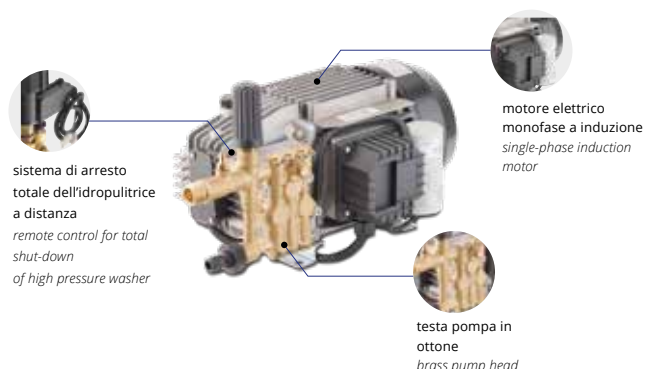

- Pompa a 3 pistoni in acciaio inox temperato con riporto ceramico con sistema biella-manovella, testa pompa in ottone
- Valvola di sicurezza automatica con azzeramento della pressione nella testa pompa
- Motore elettrico monofase a induzione con protezione termica
- Sistema di arresto totale dell'idropulitrice a distanza
- Aspirazione acqua da serbatoio con funzione autoadescente

- *Triplex pump with tempered stainless steel ceramic coated pistons and connecting rod system with brass pump head*
- *Automatic by-pass valve with pump head pressure discharge*
- *Single-phase induction motor with thermal protection*
- *Remote control for total shut-down of high pressure washer*
- *Inlet water suction from tank by self priming function*



HPE



- Pompa a 3 pistoni in ceramica con sistema biella-manovella
- Testa pompa in alluminio (Mod.625)
- Testa pompa in ottone (Mod.630/630K/650/767)
- Valvola di sicurezza automatica con azzeramento della pressione nella testa pompa
- Motore elettrico monofase a induzione con protezione termica
- Sistema di arresto totale dell'idropulitrice a distanza (Mod.767)
- Aspirazione acqua da serbatoio con funzione autoadescente

- *Triplex pump with ceramic pistons and connecting rod system*
- *Aluminum pump head (Mod.625)*
- *Brass pump head (Mod.630/630K/650/767)*
- *Automatic by-pass valve with pump head pressure discharge*
- *Single-phase induction motor with thermal protection*
- *Remote control for total shut-down of high pressure washer (Mod.767)*
- *Inlet water suction from tank by self priming function*



HJRS-O



- Pompa a 3 pistoni in acciaio inox temperato con riporto ceramico con sistema biella-manovella, testa pompa in ottone
- Valvola di sicurezza automatica con azzeramento della pressione nella testa pompa
- Motore elettrico monofase a induzione con protezione termica
- Sistema di arresto totale dell'idropulitrice a distanza
- Aspirazione acqua da serbatoio con funzione autoadescente

- *Triplex pump with tempered stainless steel ceramic coated pistons and connecting rod system with brass pump head*
- *Automatic by-pass valve with pump head pressure discharge*
- *Single-phase induction motor with thermal protection*
- *Remote control for total shut-down of high pressure washer*
- *Inlet water suction from tank by self priming function*



HRC

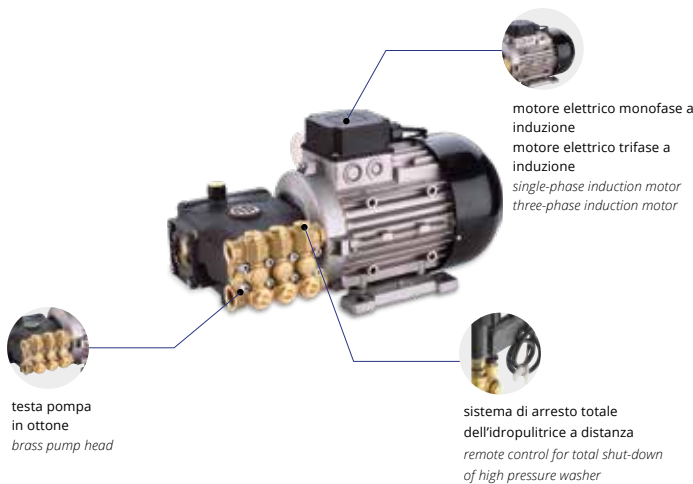

- Pompa a 3 pistoni in ceramica con sistema biella-manovella, testa pompa in ottone
- Valvola di bypass automatica con azzeramento della pressione nella testa pompa
- Motore elettrico monofase a induzione con protezione termica (3kW)
- Motore elettrico trifase a induzione con protezione termica (5kW)
- Sistema di arresto totale dell'idropulitrice a distanza
- Aspirazione acqua da serbatoio con funzione autoadescente

- *Triplex pump with ceramic pistons and connecting rod system with brass pump head*
- *Automatic by-pass valve with pump head pressure discharge*
- *Single-phase induction motor with thermal protection (3kW)*
- *Three-phase induction motor with thermal protection (5kW)*
- *Remote control for total shut-down of high pressure washer*
- *Inlet water suction from tank by self priming function*



HRR

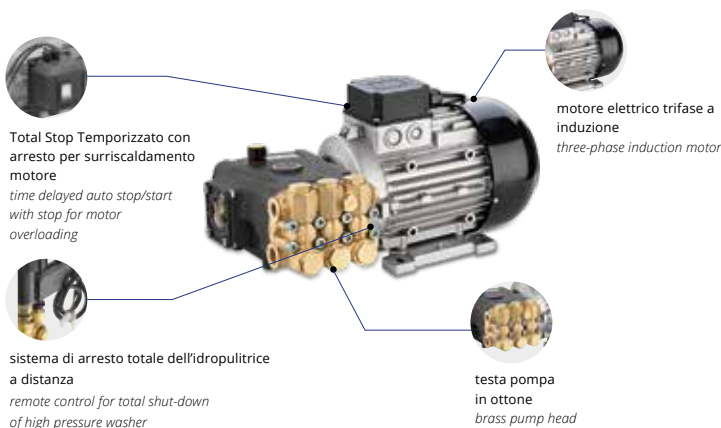

- Pompa a 3 pistoni in ceramica con sistema biella-manovella, testa pompa in ottone
- Valvola di bypass automatica con azzeramento della pressione nella testa pompa
- Motore elettrico trifase a induzione con protezione termica
- Sistema di arresto totale dell'idropulitrice a distanza
- Total Stop Temporizzato (per mod. 980,1007,1015)
- Aspirazione acqua da serbatoio con funzione autoadescente

- *Triplex pump with ceramic pistons and connecting rod system with brass pump head*
- *Automatic by-pass valve with pump head pressure discharge*
- *Three-phase induction motor with thermal protection*
- *Remote control for total shut-down of high pressure washer*
- *Time delayed auto stop/start with stop for motor overloading*
- *Inlet water suction from tank by self priming function*



HRK

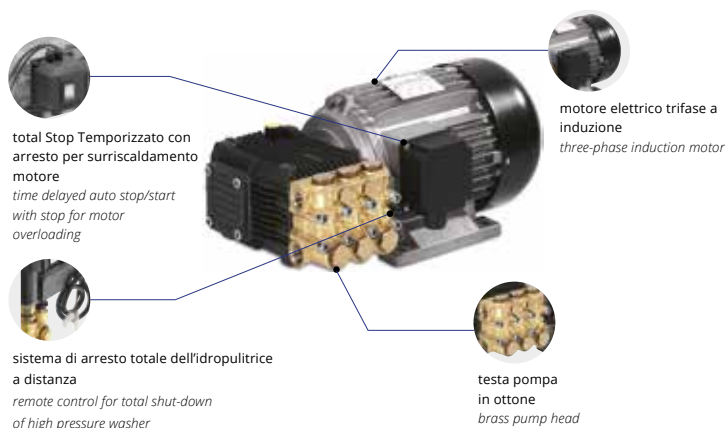

- Pompa a 3 pistoni in ceramica con sistema biella-manovella, testa pompa in ottone
- Valvola di bypass automatica con azzeramento della pressione nella testa pompa
- Motore elettrico trifase a induzione con protezione termica
- Total Stop Temporizzato
- Aspirazione acqua da serbatoio con funzione autoadescente

- Triplex pump with ceramic pistons and connecting rod system with brass pump head
- Automatic by-pass valve with pump head pressure discharge
- Three-phase induction motor with thermal protection
- Remote control for total shut-down of high pressure washer
- Time delayed auto stop/start with stop for motor overloading
- Inlet water suction from tank by self priming function



HRW

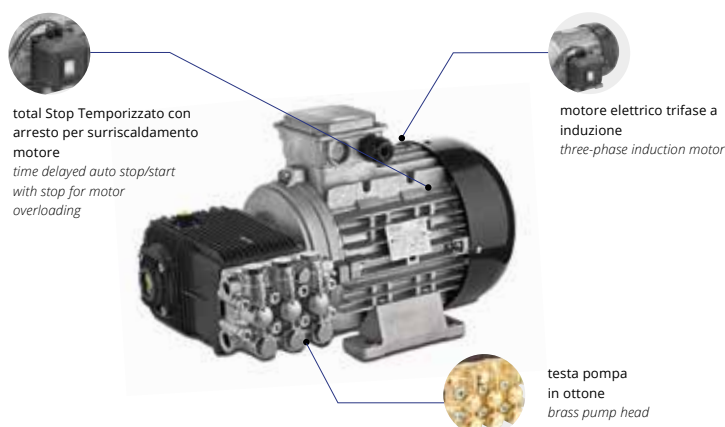

- Pompa a 3 pistoni in ceramica con sistema biella-manovella, testa pompa in ottone
- Valvola di bypass automatica con azzeramento della pressione nella testa pompa
- Motore elettrico trifase a induzione con protezione termica
- Total Stop Temporizzato
- Aspirazione acqua da serbatoio con funzione autoadescente

- Triplex pump with ceramic pistons and connecting rod system with brass pump head
- Automatic by-pass valve with pump head pressure discharge
- Three-phase induction motor with thermal protection
- Time delayed auto stop/start with stop for motor overloading
- Inlet water suction from tank by self priming function



WHW



- Pompa a 3 pistoni in ceramica con sistema biella-manovella, testa pompa in ottone
- Valvola di bypass automatica con azzeramento della pressione nella testa pompa
- Motore elettrico trifase a induzione con protezione termica
- Total Stop Temporizzato
- Guarnizioni in teflon che permettono di utilizzare acqua ad una temperatura massima in ingresso di 85°

- Triplex pump with ceramic pistons and connecting rod system with brass pump head
- Automatic by-pass valve with pump head pressure discharge
- Three-phase induction motor with thermal protection
- Time delayed auto stop/start with stop for motor overloading
- Inlet water suction from tank by self priming function
- Teflon gasket to allow cleaning at high temperature. Max inlet water temperature 85°



HXW

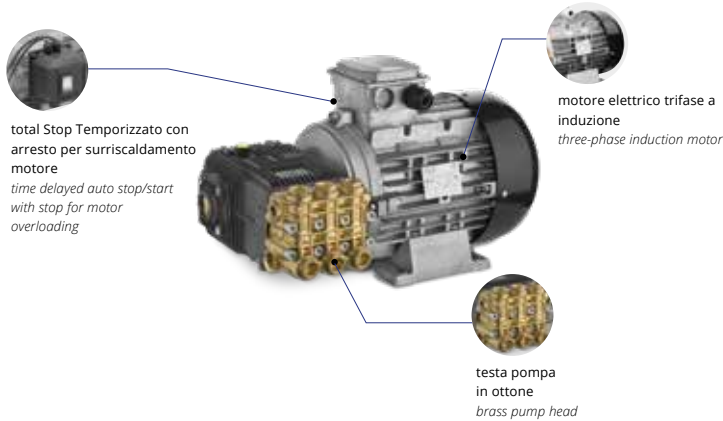

- Pompa a 3 pistoni in ceramica con sistema biella-manovella, testa pompa in ottone
 - Valvola di bypass automatica con azzeramento della pressione nella testa pompa
 - Motore elettrico trifase a induzione con protezione termica
 - Total Stop Temporizzato
 - Aspirazione acqua da serbatoio con funzione autoadescente
- *Triplex pump with ceramic pistons and connecting rod system with brass pump head*
 - *Automatic by-pass valve with pump head pressure discharge*
 - *Three-phase induction motor with thermal protection*
 - *Time delayed auto stop/start with stop for motor overloading*
 - *Inlet water suction from tank by self priming function*

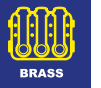

RPV

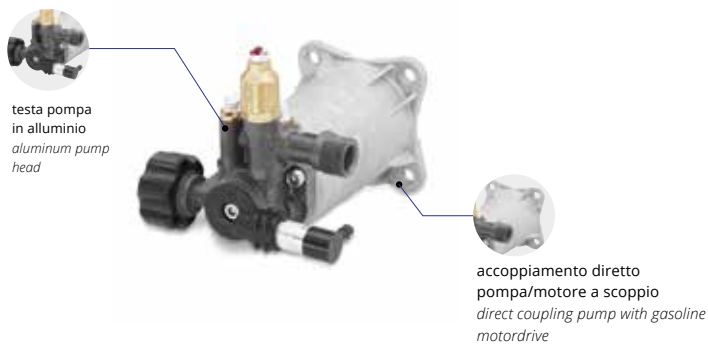

- Pompa a 3 pistoni assiali comandati dal piattello oscillante, testa alluminio
 - Pistoni in acciaio inox temperato
 - Valvola di sicurezza automatica con azzeramento della pressione nella testa pompa
 - Accoppiamento diretto pompa/motore a scoppio
 - Aspirazione acqua da serbatoio con funzione autoadescente
- *3 Axial stainless steel pistons wobble-plate pump with aluminum head*
 - *Tempered stainless steel pistons*
 - *Automatic by-pass valve with pump head pressure discharge*
 - *Direct coupling pump with gasoline motor*
 - *Inlet water suction from tank by self priming function*



RMW



- Pompa a 3 pistoni assiali comandati dal piattello oscillante, testa alluminio
 - Pistoni in acciaio inox temperato
 - Valvola di sicurezza automatica con azzeramento della pressione nella testa pompa
 - Accoppiamento diretto pompa/motore a scoppio
 - Aspirazione acqua da serbatoio con funzione autoadescente
- *3 Axial stainless steel pistons wobble-plate pump with aluminum head*
 - *Tempered stainless steel pistons*
 - *Automatic by-pass valve with pump head pressure discharge*
 - *Direct coupling pump with gasoline motor*
 - *Inlet water suction from tank by self priming function*



RMV



testa pompa in ottone
brass pump head



accoppiamento diretto pompa/motore a scoppio
direct coupling pump with gasoline motor drive



- Pompa a 3 pistoni assiali comandati dal piattello oscillante, testa ottone
 - Pistoni in acciaio inox temperato
 - Valvola di sicurezza automatica con azzeramento della pressione nella testa pompa
 - Accoppiamento diretto pompa/motore a scoppio
 - Aspirazione acqua da serbatoio con funzione autoadescente
- *3 Axial stainless steel pistons wobble-plate pump with brass head*
 - *Tempered stainless steel pistons*
 - *Automatic by-pass valve with pump head pressure discharge*
 - *Direct coupling pump with gasoline motor*
 - *Inlet water suction from tank by self priming function*



SRMV



testa pompa in alluminio
aluminum pump head

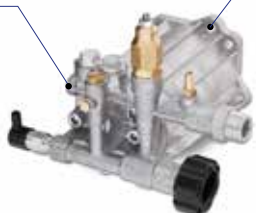

accoppiamento diretto pompa/motore a scoppio
direct coupling pump with gasoline motor drive



- Pompa a 3 pistoni assiali comandati dal piattello oscillante, testa alluminio
 - Pistoni in acciaio inox temperato
 - Valvola di sicurezza automatica con azzeramento della pressione nella testa pompa
 - Accoppiamento diretto pompa/motore a scoppio
 - Aspirazione acqua da serbatoio con funzione autoadescente
- *3 Axial stainless steel pistons wobble-plate pump with aluminum head*
 - *Tempered stainless steel pistons*
 - *Automatic by-pass valve with pump head pressure discharge*
 - *Direct coupling pump with gasoline motor*
 - *Inlet water suction from tank by self priming function*



RCV



testa pompa in ottone
brass pump head



accoppiamento diretto pompa/motore a scoppio
direct coupling pump with gasoline motor drive



- Pompa a 3 pistoni in ceramica con sistema biella-manovella, testa pompa in ottone
 - Pistoni in acciaio inox temperato
 - Valvola di sicurezza automatica con azzeramento della pressione nella testa pompa
 - Accoppiamento diretto pompa/motore a scoppio
 - Aspirazione acqua da serbatoio con funzione autoadescente
- *Triplex pump with ceramic pistons and connecting rod system with brass pump head*
 - *Tempered stainless steel pistons*
 - *Automatic by-pass valve with pump head pressure discharge*
 - *Direct coupling pump with gasoline motor*
 - *Inlet water suction from tank by self priming function*



RRV



testa pompa in ottone
brass pump head



accoppiamento diretto pompa/motore a scoppio
direct coupling pump with gasoline motor drive



- Pompa a 3 pistoni in ceramica con sistema biella-manovella, testa pompa in ottone
- Pistoni in acciaio inox temperato
- Valvola di bypass automatica con azzeramento della pressione nella testa pompa
- Accoppiamento diretto pompa/motore a scoppio
Aspirazione acqua da serbatoio con funzione autoadescente
- *Triplex pump with ceramic pistons and connecting rod system with brass pump head*
- *Tempered stainless steel pistons*
- *Automatic by-pass valve with pump head pressure discharge*
- *Direct coupling pump with gasoline motor*
- *Inlet water suction from tank by self priming function*



RKA+CR



testa pompa in ottone nichelato
nichel plated brass pump head



accoppiamento pompa/motore a scoppio con riduttore di giri
coupling pump/gasoline motor by gear box drive



- Pompa a 3 pistoni in ceramica con sistema biella-manovella, testa ottone nichelato
- Pistoni in acciaio inox temperato
- Valvola di sicurezza automatica con azzeramento della pressione nella testa pompa
- Accoppiamento pompa/motore a scoppio con riduttore di giri
Aspirazione acqua da serbatoio con funzione autoadescente
- *Triplex pump with ceramic pistons and connecting rod system with nichel plated brass head*
- *Tempered stainless steel pistons*
- *Automatic by-pass valve with pump head pressure discharge*
- *Coupling pump/gasoline motor by gear box drive*
- *Inlet water suction from tank by self priming function*





POMPE / PUMPS



	HJRS-A	HPV-O	HPE	HJRS-O	HRC	HRR	HRK	HRW
611	●							
613		●						
614		●						
613K		●						
614K		●						
630			●					
630K		●						
670				●				
671				●				
680				●				
680K				●				
930					●			
960					●			
980						●		
1003K					●			
1005K					●			
1001		●						
1003					●			
1003XE					●			
1006XE					●			
1007						●		
1007 XE						●		
1009							●	
1015						●		
1018								●
1018H								
1120								
1415								
1425								
1435								
1440								
1445								
1445XE								
1447								
1450								
1460								
1480								
1475								
1475XE								
1490								

WHW	HXW	RPV	RMW	RMV	SRMV	RCV	RRV	RKA+CR	
									611
									613
									614
									613K
									614K
									630
									630K
									670
									671
									680
									680K
									930
									960
									980
									1003K
									1005K
									1001
									1003
									1003XE
									1006XE
									1007
									1007XE
									1009
									1015
									1018
●									1018H
	●								1120
		●							1415
			●						1425
									1435
				●					1440
				●					1445
				●					1445XE
				●					1447
							●		1450
							●		1460
							●		1480
							●		1475
							●		1475XE
								●	1490

IDRO PRO COLD



SERIE 6	P 85
SERIE 9	P 94
SERIE 10	P 100
SERIE 11	P 108
SERIE 14	P 109

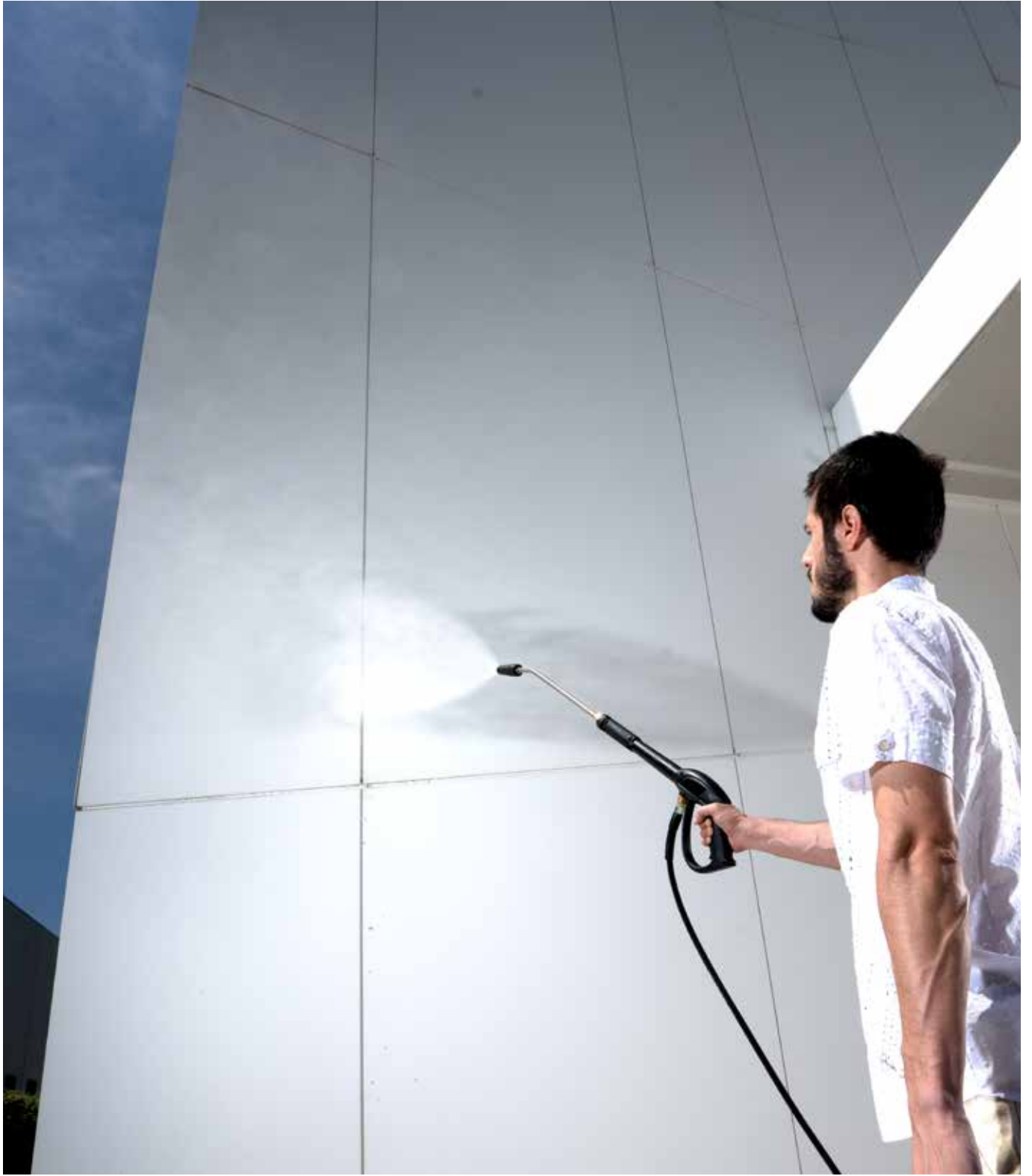

OLIGHTPRO

TRADE SELECTION



Caratteristiche Generali

- Pompa a 3 pistoni in acciaio inox temprato con sistema biella-manovella
- Valvola di sicurezza automatica con azzeramento della pressione nella testa pompa
- Motore elettrico monofase a induzione con protezione termica
- Regolazione della pressione
- Manometro

General Features

- Triplex pump with tempered stainless steel pistons and connecting rod system
- Automatic by-pass valve with pump head
- pressure discharge
- Single-phase induction motor with thermal protection
- Pressure adjustment
- Pressure gauge



MOD	COD	MAX		MAX						KG NET
		bar	psi	l/h	gph	kW	rpm	Hz	V	kg
611	15167	140	2030	500	132	2,1	2800	50	220-240~	20,1

Accessori standard Standard accessories

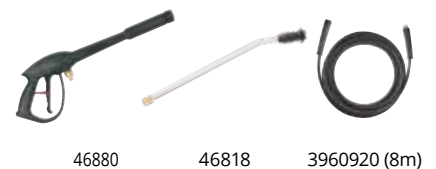

OPTIONAL / OPZIONALE
Cod. 41869



OPTIONAL / OPZIONALE
Cod. 41738



OPTIONAL / OPZIONALE
Cod. 41739





6 Series 613.614

IDROPULTRICI ALTA PRESSIONE
high pressure washers

OLIGHTPRO



portatile
portable



filtro ingresso acqua
ispezionabile
inspectable water
intake filter

Caratteristiche Generali

- Pompa a 3 pistoni in ceramica con sistema biella-manovella
- Valvola di sicurezza automatica con azzeramento della pressione nella testa pompa
- Motore elettrico monofase a induzione con protezione termica
- Regolazione della pressione
- Manometro
- Aspirazione detergente incorporata

General Features

- Triplex pump with ceramic pistons and connecting rod system
- Automatic by-pass valve with pump head pressure discharge
- Single-phase induction motor with thermal protection
- Pressure adjustment
- Pressure gauge
- Built-in detergent suction



MOD	COD	MAX		l/h	gph	kW	rpm	Hz	V	KG NET
		bar	psi							
613	13975	150	2200	500	132	2,5	2800	50	220-240~	16,8
614	13977	160	2300	510	135	2,9	2800	50	220-240~	18,4

Accessori standard Standard accessories



43471

43472
(613)
41806
(614)

43473 (8 m)



OPTIONAL / OPZIONALE
Cod. 41869

Carrello con manico orientabile
Orientable holder

ø 25cm

OPTIONAL / OPZIONALE
Cod. 41738

Kit avvolgitubo per carrello
Hose reel kit trolley version

OPTIONAL / OPZIONALE
Cod. 41739

Unità di montaggio a muro senza tubo
Wall mounted kit without hose

OPTIONAL / OPZIONALE
Cod. 41880

Unità di montaggio a muro con tubo 15m
Wall mounted kit with 15m hose



OLIGHTPRO

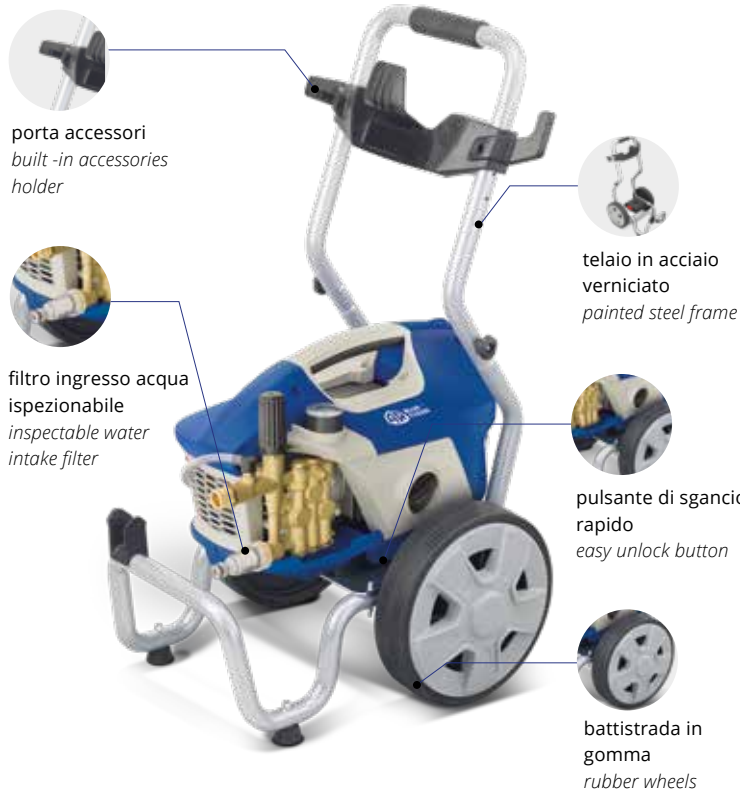

Caratteristiche Generali

- Carrello a 2 ruote completo di manico
- Pompa a 3 pistoni in ceramica con sistema biella-manovella
- Valvola di sicurezza automatica con azzeramento della pressione nella testa pompa
- Motore elettrico monofase a induzione con protezione termica
- Regolazione della pressione
- Manometro
- Aspirazione detergente incorporata

General Features

- Two-wheel trolley with handle
- Triplex pump with ceramic pistons and connecting rod system
- Automatic by-pass valve with pump head
- pressure discharge
- Single-phase induction motor with thermal protection
- Pressure adjustment
- Pressure gauge
- Built-in detergent suction



MOD	COD	MAX		l/h	gph	kW	rpm	Hz	V	KG NET
		bar	psi							
613K	13976	150	2200	500	132	2,5	2800	50	220-240~	23
614K	13978	160	2300	510	135	2,9	2800	50	220-240~	24,6

Accessori standard Standard accessories

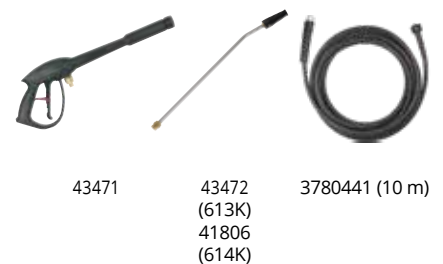



WALL MOUNTED & KART UNIT

- 1** UNITÀ DI MONTAGGIO A MURO
Wall mounted kit
- 2** KIT AVVOLGITUBO A MURO
Wall mounted hose reel
- 3** TUBO AD ALTA PRESSIONE DI 15M
HP 15mt hose.
- 4** PULSANTE DI SGANCIO RAPIDO
Easy unlock button
- 5** RUOTE AD ALTA STABILITÀ
High stability wheels
- 6** KIT CARRELLO CON TELAIO PIEGHEVOLE IN ACCIAIO VERNICIATO
Trolley kit with foldable painted steel frame
- 7** PORTA ACCESSORI INTEGRATO
Built-in accessory holder



UNITÀ DI MONTAGGIO A MURO

AR COD. 41880
EAN COD. 8016287418805

Kit avvolgitubo a muro con tubo ad alta pressione di 15m.

WALL MOUNTED UNIT

Wall mounted hose reel with HP hose 15m hose.

KIT CARRELLO

AR COD. 41869
EAN COD. 8016287418690

Telaio pieghevole in acciaio verniciato con grandi ruote durature di ø250mm per un migliore bilanciamento.

TROLLEY KIT

Foldable painted steel frame with durable rubber wheels ø250mm for perfect balancing.





6 Series 630

IDROPULTRICI ALTA PRESSIONE
high pressure washers

OLIGHTPRO



portatile
portable



filtro ingresso acqua
ispezionabile
inspectable water
intake filter



Caratteristiche Generali

- Pompa a 3 pistoni in ceramica con sistema biella-manovella
- Valvola di sicurezza automatica con azzeramento della pressione nella testa pompa
- Motore elettrico monofase a induzione con protezione termica
- Regolazione della pressione
- Manometro
- Aspirazione detergente incorporata

General Features

- Triplex pump with ceramic pistons and connecting rod system
- Automatic by-pass valve with pump head pressure discharge
- Single-phase induction motor with thermal protection
- Pressure adjustment
- Pressure gauge
- Built-in detergent suction

 INDUCTION	 ROD-CRANK	HPE	 BRASS
 MAX 60°C 140°F	 IPX5-S1	SPF Self Priming FUNCTION	

MOD	COD	 MAX	 MAX		 KG NET					
		bar	psi	l/h	gph	kW	rpm	Hz	V	kg
630	12360	120	1740	600	159	2,6	1450	50	230~	27
630K	14633	120	1740	600	159	2,6	1450	50	230~	34,5



Accessori standard Standard accessories



43471 630 - 40039 1271351 (10 m)
630K - 46056

OPTIONAL / OPZIONALE Cod. 43972 Orientable holder ø 25cm	630K OPTIONAL / OPZIONALE Cod. 41738 Hose reel without hose	630K OPTIONAL / OPZIONALE Cod. 41739 Wall mounted kit without hose	630K OPTIONAL / OPZIONALE Cod. 41880 Wall mounted kit with 15m hose
--	--	---	--

OLIGHTPRO



Caratteristiche Generali

- Pompa a 3 pistoni in ceramica con sistema biella-manovella
- Valvola di sicurezza automatica con azzeramento della pressione nella testa pompa
- Motore elettrico monofase a induzione con protezione termica
- Regolazione della pressione
- Manometro
- Aspirazione detergente incorporata

General Features

- Triplex pump with ceramic pistons and connecting rod system
- Automatic by-pass valve with pump head pressure discharge
- Single-phase induction motor with thermal protection
- Pressure adjustment
- Pressure gauge
- Built-in detergent suction



MOD	COD	MAX		MAX							KG NET
		bar	psi	l/h	gph	kW	rpm	Hz	V	kg	
670	14680	160	2300	500	132	2,5	2800	50	220-240~	20	
671	14697	180	2600	510	135	2,9	2800	50	220-240~	23,6	

Accessori standard Standard accessories



OPTIONAL / OPZIONALE
Cod. 43972



ø 25cm

OPTIONAL / OPZIONALE
Cod. 41738



Kit avvolgitubo per carrello
Hose reel kit trolley version



6 Series 680.680K

IDROPULTRICI ALTA PRESSIONE
high pressure washers

OLIGHTPRO

TRADE
SELECTION



valvole ispezionabili
inspectable valves

tappo scarico olio inferiore
lower oil drain plug

portatile
portable

interruttore rotativo
rotary switch



Caratteristiche Generali

- Pompa a 3 pistoni in ceramica con sistema biella-manovella
- Valvola di sicurezza automatica con azzeramento della pressione nella testa pompa
- Motore elettrico monofase a induzione con protezione termica
- Regolazione della pressione
- Manometro

General Features

- Triplex pump with ceramic pistons and connecting rod system
- Automatic by-pass valve with pump head pressure discharge
- Single-phase induction motor with thermal protection
- Pressure adjustment
- Pressure gauge



MOD	COD	MAX	MAX		NET					
		bar	psi	l/h	gph	kW	rpm	Hz	V	kg
680	15267	150	2200	600	160	2,6	2800	50	220-240~	20,8
680K	15268	150	2200	600	160	2,6	2800	50	220-240~	25,3

Accessori standard Standard accessories

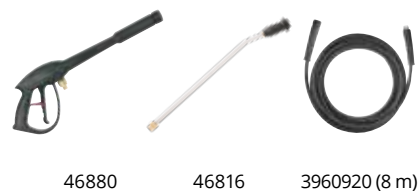

46880

46816

3960920 (8 m)



OPTIONAL / OPZIONALE
Cod. 43972

Carrello con
manico orientabile
Orientable holder

ø 25cm

OPTIONAL / OPZIONALE
Cod. 41738

Kit avvolgitubo senza tubo
Hose reel without hose

OPTIONAL / OPZIONALE
Cod. 41739

Unità di montaggio a muro
senza tubo
Wall mounted kit without hose



TST[®]
Total Stop
SYSTEM
TIMED



Nata a Modena

Born in Modena

9 SERIES

La nuova Serie 9 è il match perfetto tra design e prestazioni professionali. Nata a Modena, negli stabilimenti dedicati al cleaning, quest'idropultrice ad acqua fredda ha delle dimensioni compatte e vanta un'estrema manovrabilità, che la rendono al tempo stesso robusta e maneggevole. L'impugnatura del manico è stata progettata per facilitarne l'utilizzo, come anche i diversi punti di rimessaggio accessori sulla macchina. Il pratico porta lancia, sul fianco della macchina ed il gancio per il tubo alta pressione nella parte posteriore. Si tratta di una gamma di idropultrici con dotazione completa e professionale, equipaggiate con accessori ideali per utilizzi continuativi e complessi.

9 SERIES

The new Series 9 is the perfect match of design and professional performance. Created in Modena, in the plants that specialise in cleaning equipment, this cold water high pressure washer is compact in size and very manoeuvrable, making it both sturdy and agile. The handle grip is styled for user-friendliness, as are the various accessory stowing points on the appliance. These include the handy lance holder on the side of the appliance and the high pressure hose hook at the rear. It is a high pressure washer range with a full, professional outfit, equipped with the ideal accessories for continuous use on complex jobs.

UNIQUE DETAILS

- 1** MANUBRIO ERGONOMICO
Ergonomic handle
- 2** PORTA ACCESSORI INTEGRATI
Built-in accessories holders
- 3** RUOTE AD ALTA STABILITÀ
High stability wheels ø 35 cm
- 4** PRESSIONE REGOLABILE
Pressure adjustment
- 5** MANOMETRO
Pressure gauge
- 6** FILTRO ACQUA ISPEZIONALE
Inspectable water filter

THE POWER OF CLEANING

Grazie all'elevata pressione ed alle notevoli portate, le idropultrici della SERIE 9, riescono a rimuovere con estrema facilità lo sporco più ostinato ed incrostato dalle grandi superfici. Le prestazioni di queste idropultrici sono state studiate per soddisfare al meglio questo genere di esigenze, specialmente nel settore edile ed automotive.

THE POWER OF CLEANING

Thanks to their high pressures and flow rates, SERIES 9 high pressure washers can remove the most stubborn, firmly encrusted dirt from large surfaces. These high pressure washers have performance levels designed to tackle needs of this kind with the greatest success, especially in the construction and automotive sectors.



9SERIES





HEAVYPRO



Caratteristiche Generali

- Carrello a due ruote completo di manico
- Pompa a 3 pistoni in ceramica, con sistema biella-manovella
- Valvola di bypass automatica con azzeramento della pressione nella testa pompa
- Motore elettrico monofase a induzione con protezione termica
- Regolazione della pressione
- Manometro
- Aspirazione detergente incorporata
- Aspirazione detergente regolabile

General Features

- Two-wheel trolley unit with handle
- Triplex pump with ceramic pistons and connecting rod system
- Automatic bypass valve with pressure shut-off at pump head
- Single-phase induction motor with thermal protection
- Pressure adjustment
- Pressure gauge
- Built-in detergent suction
- Adjustable detergent injector

930	960	980
HRC	HRC	HRR

INDUCTION	ROD-CRANK	BRASS	SPF Self Priming Function
MAX 60°C 140°F	IPX5-S1	TSS® Total Stop SYSTEM	TST® Total Stop SYSTEM TIMED

930.960 980

MOD	COD	MAX		MAX						KG NET
		bar	psi	l/h	gph	kW	rpm	Hz	V	kg
930	14261	150	2200	630	166	3	1450	50	230~	43,6
960	15479	200	2900	840	221	5	1450	50	400 3~	45,5
980	15480	230	3335	900	238	7,4	1450	50	400 3~	52,2

Accessori standard Standard accessories



46880 (930.960) 41929 (930) 3960970 (10 m) (930)
3961050 (10 m) (960.980)

47039 (980) 46221 (960.980) 3086 (960/980 - 15045)









10 Series 1003K.1005K

IDROPULTRICI ALTA PRESSIONE
high pressure washers

HEAVYPRO



Caratteristiche Generali

- Carrello robusto in metallo a due ruote completo di manico
- Pompa a pistoni con sistema biella-manovella ad elevate prestazioni
- Valvola di by-pass automatica con azzeramento della pressione nella testa della pompa
- Motore elettrico a induzione monofase con protezione termica (mod. 1003K)
- Motore elettrico a induzione trifase con protezione termica (mod. 1004K/1005K)
- Regolazione della pressione
- Manometro
- Aspirazione detergente
- Filtro acqua ispezionabile

General Features

- Heavy-duty two wheeled trolley with handle
- High performance piston pump with connecting rod system
- Automatic by-pass valve with pressure with pump head pressure discharge
- Single-phase induction motor with thermal protector (mod. 1003K)
- Three-phase induction motor with thermal protector (mod. 1004K/1005K)
- Pressure adjustment
- Pressure gauge
- Detergent suction
- Inspectable water filter



MOD	COD	MAX		MAX						KG NET
		bar	psi	l/h	gph	kW	rpm	Hz	V	
1003K	25543	150	2200	630	166	3	1450	50	230~	35,6
1005K	15500	180	2610	900	238	5	1450	50	400 3~	37,6

Accessori standard Standard accessories



43471 (1003K)	41747 (1003K)	3780441 (1003K - 10 m)
46880 (1005K)	41748 (1005K)	3960970 (1005K - 10 m)





OLIGHTPRO



telaio in acciaio verniciato
painted steel frame

filtro ingresso
acqua ispezionabile
inspectable water
intake filter

porta accessori
built-in accessories holder

serbatoio detergente
integrato
built-in detergent tank

battistrada in
gomma
rubber wheels



Caratteristiche Generali

- Carrello robusto in metallo a due ruote completo di manico
- Pompa a 3 pistoni in ceramica, con sistema biella-manovella
- Valvola di sicurezza automatica con azzeramento della pressione nella testa della pompa
- Motore elettrico a induzione monofase con protezione termica
- Regolazione della pressione
- Manometro
- Aspirazione detergente incorporata
- Aspirazione detergente regolabile
- Capacità del serbatoio detergente 3 l
- Filtro acqua ispezionabile

General Features

- Heavy-duty two wheeled trolley with handle
- Triplex pump with ceramic pistons and connecting rod system
- Automatic safety valve with pressure with pump head pressure discharge
- Single-phase induction motor with thermal protector
- Pressure adjustment
- Pressure gauge
- Built-in detergent suction
- Adjustable detergent injector
- Built-in detergent tank capacity 3 l
- Inspectable water filter



MOD	COD	MAX		MAX					KG NET	
		bar	psi	l/h	gph	kW	rpm	Hz	V	kg
1001	24384	150	2200	500	132	2,5	2800	50	230~	26,8

Accessori standard

Standard accessories



43471 3600650 3600620 (10 m)



- 3600400 (low pressure) Nero/Black
- 3600440 (0003) Rosso/Red
- 3600450 (1503) Giallo/Yellow
- 3600460 (2503) Verde/Green
- 3600470 (4003) Bianco/White





10 Series 1003.1003XE.1006XE

IDROPULTRICI ALTA PRESSIONE
high pressure washers

HEAVYPRO

1003XE-1006XE
**TRADE
SELECTION**



telaio in acciaio verniciato
painted steel frame



filtro ingresso
acqua ispezionabile
inspectable water
intake filter



porta accessori
built-in accessories holder



serbatoio detergente
integrato
built-in detergent tank



battistrada in
gomma
rubber wheels



Caratteristiche Generali

- Carrello robusto in metallo a due ruote completo di manico
- Pompa a 3 pistoni in ceramica, con sistema biella-manovella
- Valvola di by-pass automatica con azzeramento della pressione nella testa della pompa
- Motore elettrico a induzione monofase con protezione termica
- Regolazione della pressione
- Manometro
- Aspirazione detergente incorporata
- Aspirazione detergente regolabile
- Capacità del serbatoio detergente 3 l
- Filtro acqua ispezionabile

General Features

- Heavy-duty two wheeled trolley with handle
- Triplex pump with ceramic pistons and connecting rod system
- Automatic by-pass valve with pressure with pump head pressure discharge
- Single-phase induction motor with thermal protector
- Pressure adjustment
- Pressure gauge
- Built-in detergent suction
- Adjustable detergent injector
- Built-in detergent tank capacity 3 l
- Inspectable water filter



MOD	COD	MAX		MAX						KG NET
		bar	psi	l/h	gph	kW	rpm	Hz	V	
1003	24385	150	2200	630	166	3	1450	50	230~	40,6
1003 RLW	24389	150	2200	630	166	3	1450	50	230~	53
1003XE	15165	150	2200	630	166	3	1450	50	230~	40,6
1006XE	15475	200	2900	840	221	5	1450	50	400 3~	51,9



46635 (1003XE)
46639 (1006XE)

1271960 (10 m - 1003-1003XE)
3161050 (10 m - 1006XE)
2500390 (10 m - 1003RLW)

Accessori standard Standard accessories

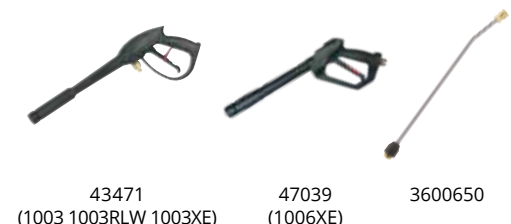

43471
(1003 1003RLW 1003XE)

47039
(1006XE)

3600650

1003.1003RLW. 1003XE
3600400 (low p.)
3600350 (0004)
3600360 (1504)
3600370 (2504)
3600380 (4004)

1006XE
3600400 (low p.)
3600480 (0005)
3600490 (1505)
3600500(2505)
3600510 (4005)

Nero/Black
Rosso/Red
Giallo/Yellow
Verde/Green
Bianco/White



HEAVYPRO



telaio in acciaio verniciato
painted steel frame



filtro ingresso
acqua ispezionabile
inspectable water
intake filter



porta accessori
built-in accessories holder



serbatoio detergente
integrato
built-in detergent tank



battistrada in
gomma
rubber wheels

**1007XE
TRADE
SELECTION**



Caratteristiche Generali

- Carrello robusto in metallo a due ruote completo di manico
- Pompa a 3 pistoni in ceramica, con sistema biella-manovella
- Valvola di by-pass automatica con azzeramento della pressione nella testa della pompa
- Motore elettrico a induzione trifase con protezione termica
- Regolazione della pressione
- Manometro
- Valvola di regolazione flangiata (VRZ)
- Aspirazione detergente incorporata
- Aspirazione detergente regolabile
- Capacità del serbatoio detergente 3 l
- Filtro acqua ispezionabile

General Features

- Heavy-duty two wheeled trolley with handle
- Triplex pump with ceramic pistons and connecting rod system
- Automatic by-pass valve with pressure with pump head pressure discharge
- Three-phase induction motor with thermal protector
- Pressure adjustment
- Pressure gauge
- Flanged pressure unloader (VRZ)
- Built-in detergent suction
- Adjustable detergent injector
- Built-in detergent tank capacity 3 l
- Inspectable water filter



MOD	COD	MAX		MAX						KG NET
		bar	psi	l/h	gph	kW	rpm	Hz	V	kg
1007	15477	230	3335	900	238	7,4	1450	50	400 3~	54,8
1007RLW	15478	230	3335	900	238	7,4	1450	50	400 3~	61,6
1007XE	15476	230	3335	900	238	7,4	1450	50	400 3~	55,3



Accessori standard Standard accessories

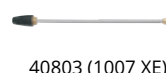

1007.1007 RLW. 1007XE
3600400 (low p.) Nero/Black
3600480 (00045) Rosso/Red
3600490 (15045) Giallo/Yellow
3600500 (25045) Verde/Green
3600510 (40045) Bianco/White



10 Series 1009RLW

IDROPULTRICI ALTA PRESSIONE
high pressure washers

HEAVYPRO



avvolgituro con tubo A.P. 15m
hose reel with 15m H.P. hose



telaio in acciaio
verniciato
painted steel frame



porta accessori
built-in accessories holder



kit aspirazione detergente
integrata
built-in detergent suction kit



battistrada in
gomma
rubber wheels

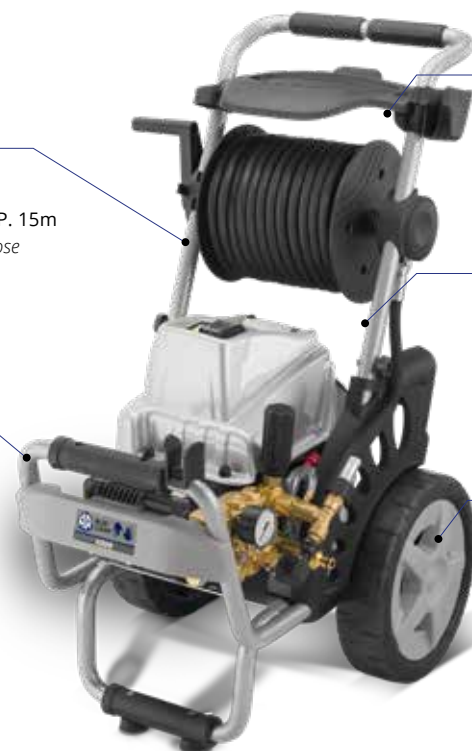

Caratteristiche Generali

- Carrello robusto in metallo a due ruote completo di manico ed avvolgitubo in pressione
- Pompa a 3 pistoni in ceramica, con sistema biella-manovella
- Valvola di by-pass automatica con azzeramento della pressione nella testa della pompa
- Motore elettrico a induzione trifase con protezione termica
- Regolazione della pressione
- Manometro
- Valvola di regolazione flangiata (VR)
- Aspirazione detergente
- Filtro acqua ispezionabile

General Features

- Heavy-duty two wheeled trolley with handle and in-pressure hose reel
- Triplex pump with ceramic pistons and connecting rod system
- Automatic by-pass valve with pressure with pump head pressure discharge
- Three-phase induction motor with thermal protector
- Pressure adjustment
- Pressure gauge
- Flanged pressure unloader (VR)
- Detergent injector
- Inspectable water filter

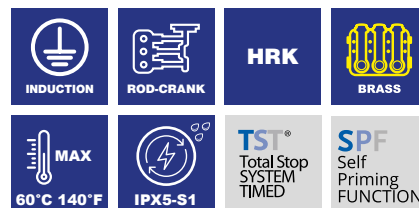

MOD	COD	MAX	MAX				NET			
		bar	psi	l/h	gph	kW	rpm	Hz	V	kg
1009 RLW	15354	200	2900	1260	333	9,3	1450	50	400 3~	67,5

Accessori standard Standard accessories



47039

46221
(56 cm)

3600970
(15 m)



3090
(2507)



NEW

HEAVYPRO



Caratteristiche Generali

- Struttura robusta con cofano in acciaio inox
- Pompa a 3 pistoni in ceramica con sistema biella- manovella
- Valvola di by-pass automatica con azzeramento della pressione nella testa della pompa
- Motore elettrico trifase
- Valvola di regolazione flangiata (Gymatic 3/B - ID)
- Regolazione pressione
- Aspirazione detergente incorporata

General Features

- Heavy-duty frame with stainless steel cover
- Triplex pump with ceramic pistons and connecting rod system
- Automatic by-pass valve with pump head pressure discharge
- Heavy-duty three-phase motor
- Flanged unloader valve (Gymatic 3/B - ID)
- Pressure adjustment
- Built-in detergent suction



MOD	COD	MAX		MAX						KG NET
		bar	psi	l/h	gph	kW	rpm	Hz	V	kg
1015	25283	200	2900	900	238	7,4	1450	50	400 3~	60



Accessori standard Standard accessories





10 Series 1018

IDROPULTRICI ALTA PRESSIONE
high pressure washers

HEAVYPRO



Caratteristiche Generali

- Struttura robusta con cofano in acciaio inox
- Pompa a 3 pistoni in ceramica con sistema biella- manovella
- Valvola di by-pass automatica con azzeramento della pressione nella testa della pompa
- Motore elettrico trifase
- Flangia con giunto elastico per accoppiamento pompa-motore
- Valvola di regolazione flangiata
- Regolazione pressione
- Aspirazione detergente incorporata

General Features

- Heavy-duty frame with stainless steel cover
- Triplex pump with ceramic pistons and connecting rod system
- Automatic by-pass valve with pump head pressure discharge
- Heavy-duty three-phase motor
- Flange with elastic joint for pump-motor coupling
- Flanged unloader valve
- Pressure adjustment
- Built-in detergent suction

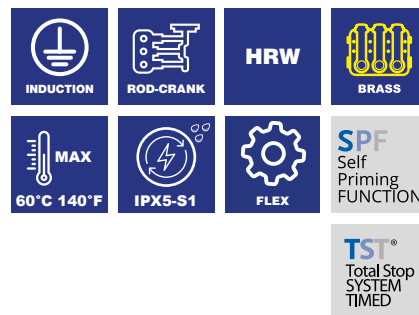

MOD	COD	MAX		MAX					KG NET	
		bar	psi	l/h	gph	kW	rpm	Hz	V	kg
1018	24491	200	2900	900	238	7,4	1450	50	400 3~	80

Accessori standard Standard accessories



HEAVYPRO

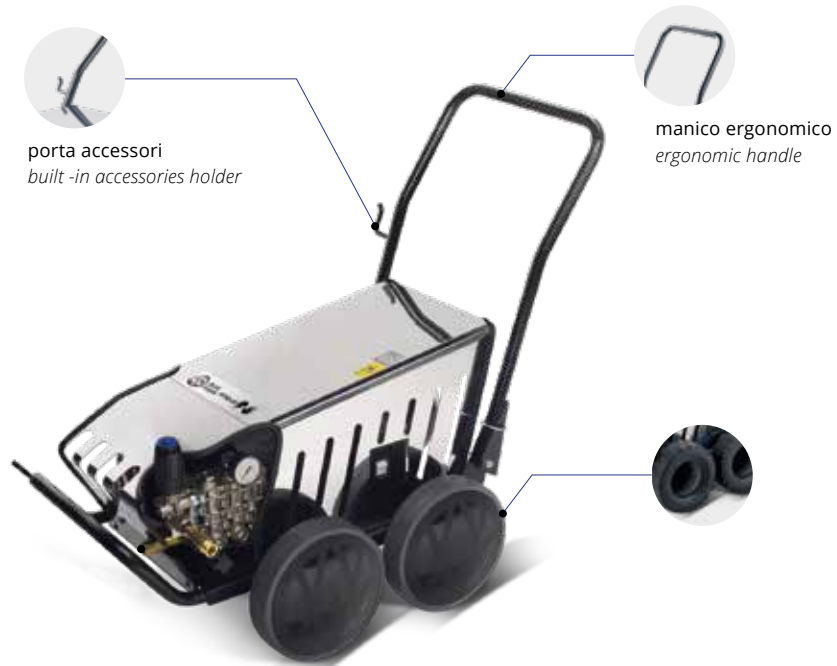

Caratteristiche Generali

- Struttura robusta con cofano in acciaio inox
- Pompa a 3 pistoni in ceramica con sistema biella- manovella
- Guarnizioni in teflon che permettono di utilizzare acqua ad una temperatura massima in ingresso di 85°
- Valvola di by-pass automatica con azzeramento della pressione nella testa della pompa
- Motore elettrico trifase
- Flangia con giunto elastico per accoppiamento pompa-motore
- Valvola di regolazione flangiata
- Regolazione pressione

• General Features

- Heavy-duty frame with stainless steel cover
- Triplex pump with ceramic pistons and connecting rod system
- Teflon gasket to allow cleaning at high temperature. Max inlet water temperature 85°
- Automatic by-pass valve with pump head pressure discharge
- Heavy-duty three-phase motor
- Flange with elastic joint for pump-motor coupling
- Flanged unloader valve
- Pressure adjustment

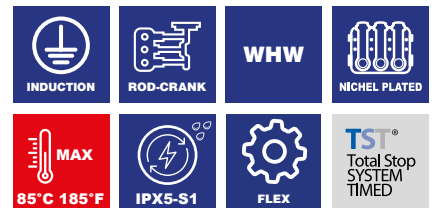

MOD	COD	MAX		MAX					KG NET	
		bar	psi	l/h	gph	kW	rpm	Hz	V	kg
1018H	25272	200	2900	900	238	7,4	1450	50	400 3~	80



Accessori standard Standard accessories





11 Series 1120

IDROPULTRICI ALTA PRESSIONE
high pressure washers

HEAVYPRO



Caratteristiche Generali

- Struttura robusta con cofano in acciaio inox
- Pompa a 3 pistoni in ceramica con sistema biella- manovella
- Testa pompa in ottone
- Valvola di by-pass automatica con azzeramento della pressione nella testa della pompa
- Arresto per microperdite
- Arresto dopo 1 ora di Total Stop
- Arresto per mancanza d'acqua
- Arresto per surriscaldamento motore
- Segnalazione d'errore tramite spia intermittente
- Motore elettrico trifase
- Regolazione pressione
- Aspirazione detergente incorporata

General Features

- Heavy-duty frame with stainless steel cover
- Triplex pump with ceramic pistons and connecting rod system
- Brass pump head
- Automatic by-pass valve with pump head pressure discharge
- Stop for leak detention
- Stop after 1 hour of total stop
- Stop for lack of water
- Stop for motor overloading
- System error warning light
- Heavy-duty three-phase motor
- Pressure adjustment
- Built-in detergent suction

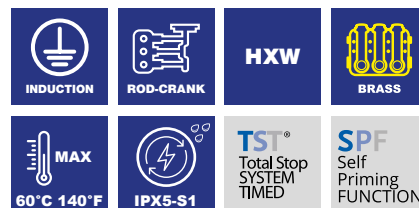

MOD	COD	MAX	MAX							KG NET
		bar	psi	l/h	gph	kW	rpm	Hz	V	kg
1120	22374	200	2900	1260	333	9,3	1450	50	400 3~	110

Accessori standard Standard accessories



GAMMA CON PRESTAZIONI ELEVATE

TOP-OF-THE LINE RANGE



14 NEW SERIES

Gamma completa e profonda di idropulitrici con motore a scoppio, che non necessitano di alimentazione elettrico, perfette quindi per utilizzi in cantieri e nel settore edile.

I telai robusti ed ergonomici assicurano un'extra durata ed i pneumatici gonfiabili ed i larghi battistrada rivestiti in gomma garantiscono un'estrema manovrabilità anche sulle superfici più sconnesse. Dotazione di accessori professionali per garantire sempre una potenza eccezionale ed un perfetto potere pulente.

14 NEW SERIES

A wide, complete range of high pressure washers with internal combustion engines, which do not need an electricity supply and are therefore perfect for uses on construction sites and in the building industry.

The rugged, ergonomic frames guarantee exceptional durability and the inflatable tyres and wide rubber treads ensure excellent manoeuvrability on even the most uneven ground.

A range of professional accessories to guarantee outstanding power and perfect cleaning power at all times.

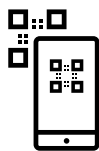

- **FACILE DA MANOVRARE**
EASY-TO-MOVE
- **DESIGN ERGONOMICO**
ERGONOMIC DESIGN
- **MASSIMA FLESSIBILITÀ**
EXTREME FLEXIBILITY



UNIQUE DETAILS

- 1** ROBUSTO CARRELLO IN METALLO
Solid metal frame
- 2** BATTISTRADA RICOPERTI IN GOMMA
Rubber tread wheels
- 3** PORTA-ACCESSORI INTEGRATO
Built-in accessories holder
- 4** PIEDINI ANTI-VIBRAZIONE
Anti-vibration feet
- 5** PNEUMATICI GONFIABILI AD ALTA AFFIDABILITÀ
Never-go-flat wheels
- 6** PRATICA IMPUGNATURA ANTI-SCIVOLO
Soft-grip handle

COMPATTA E INDIPENDENTE SENZA ELETTRICITÀ

COMPACT & INDEPENDENT



14 New Series

THE POWER OF CLEANING

Idropultrici extra-flessibili - indipendenti dall'alimentazione elettrica. Alimentate a benzina o diesel, sono la soluzione ideale per la pulizia nel settore agricolo ed edile dove sono richieste prestazioni elevate ed un'estrema manovrabilità. Robuste e prestanti sono la risposta migliore per questo tipo di utilizzi gravosi e continuati. Le pompe montate su queste idropultrici sono costruite utilizzando esclusivamente materiali di qualità e anti-corrosione, quali l'ottone. Offrono quindi una lunga durata ed un'estrema facilità di manutenzione.

THE POWER OF CLEANING

Highly versatile high pressure washers - with no electricity supply needed. Operating on petrol or diesel, they are the ideal solution for cleaning in the farming and construction sectors, where high performance and extreme manoeuvrability are required. Tough and high-performing, they are the best solution for this type of heavy-duty, continuous use. The pumps installed on these high pressure washers are built only from top quality, corrosion-resistant materials, such as brass. This ensures a long working lifetime and exceptionally easy maintenance.



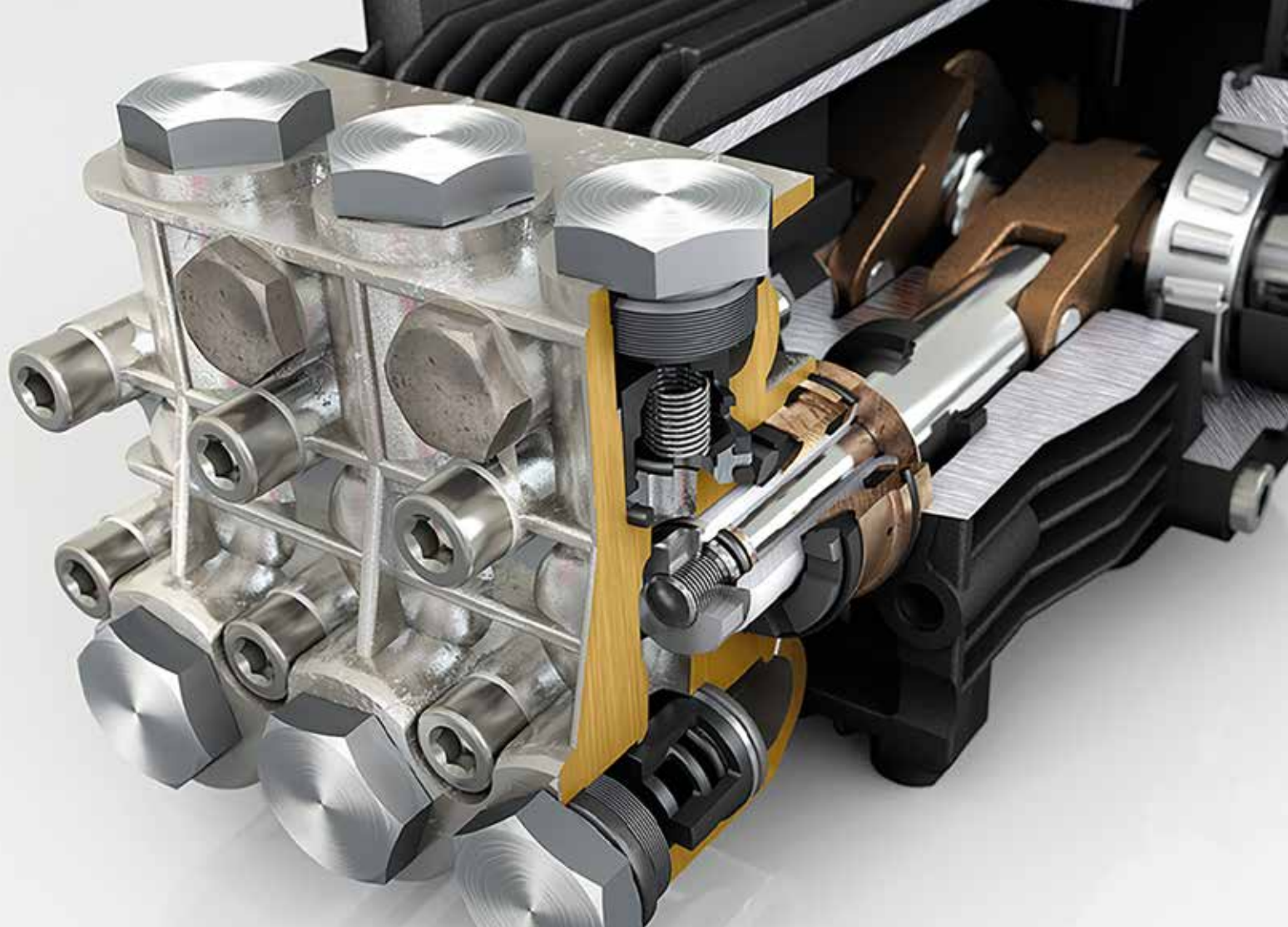

POMPA modello RK

PUMP MODEL RK

POMPA AR AD ALTE PRESTAZIONI
Long-lasting ar pump

TESTA POMPA IN OTTONE FORGIATO
Forged brass pump head

SISTEMA BIELLA-MANOVELLA
Connecting rod-system

CONTROLLO QUALITÀ AR GARANTITA AL 100%
100% Ar quality control system





OLIGHTPRO



Caratteristiche Generali

- Telaio completo di manico con piedini antivibranti
- Pompa a 3 pistoni assiali comandati dal piattello oscillante
- Valvola di sicurezza automatica
- Valvola termica
- Aspirazione detergente incorporata
- Aspirazione detergente regolabile
- Motorizzato Lifan (benzina), con sensore mancanza olio
- Livelli olio ispezionabili
- Tappi ed asole di scarico per agevolare la manutenzione ed il cambio olio
- Filtro acqua ispezionabile
- Soluzioni studiate per ottimizzare gli ingombri

General Features

- Metal frame with handle and anti-vibrating feet
- 3 Axial stainless steel pistons wobble-plate pump
- Automatic safety valve
- Thermal valve
- Built-in detergent suction
- Powered by Lifan petrol engine with low oil level sensor
- Inspectable oil levels
- Discharge plugs and discharge slots to make easy the maintenance and the oil change
- Inspectable water filter
- Space-saving solutions



MOD	COD	MAX	MAX			Engine	Engine Type	kg NET	
		bar	psi	l/h	gph	rpm			
1415	26213	130	1900	420	111	3400	152F	LIFAN	17,3

Accessori standard Standard accessories





14 Series 1425

IDROPULTRICI CON MOTORE A SCOPPIO
petrol engine pressure washers

OLIGHTPRO



porta accessori
built-in accessories holder

manico ergonomico
ergonomic handle

filtro ingresso
acqua ispezionabile
inspectable water
intake filter

valvola termica
thermal valve

battistrada in gomma
rubber wheels

telaio in acciaio
verniciato
painted steel frame

Caratteristiche Generali

- Carrello completo di manico con due ruote e piedini antivibranti
- Pompa a 3 pistoni assiali comandati dal piattello oscillante
- Valvola di sicurezza automatica
- Regolazione della pressione
- Valvola termica
- Aspirazione detergente incorporata
- Motorizzato Rato (benzina)
- Livelli olio ispezionabili
- Tappi ed asole di scarico per agevolare la manutenzione ed il cambio olio
- Filtro acqua ispezionabile
- Soluzioni studiate per ottimizzare gli ingombri

General Features

- Two-wheel trolley with tyres, handle and anti-vibrating feet
- 3 Axial stainless steel pistons wobble-plate pump
- Automatic safety valve
- Thermal valve
- Built-in detergent suction
- Powered by Rato petrol engine
- Inspectable oil levels
- Discharge plugs and discharge slots to make easy the maintenance and the oil change
- Inspectable water filter
- Space-saving solutions



MOD	COD	MAX	MAX			Engine	Engine Type	kg	
		bar	psi	l/h	gph	rpm			
1425	26215	160	2300	480	127	3400	EHRV175	RATO	25,9



Accessori standard Standard accessories

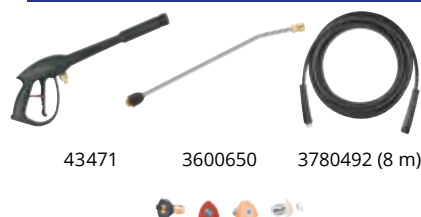

- 3600400 (low pressure) Nero/Black
- 3600440 (0003) Rosso/Red
- 3600450 (1503) Giallo/Yellow
- 3600470 (4003) Bianco/White



OLIGHTPRO



Caratteristiche Generali

- Carrello completo di manico con due ruote e piedini antivibranti
- Pompa a 3 pistoni assiali comandati dal piattello oscillante
- Valvola di sicurezza automatica
- Regolazione della pressione
- Valvola termica
- Aspirazione detergente incorporata
- Motorizzato Loncin (benzina), con sensore mancanza olio
- Livelli olio ispezionabili
- Tappi ed asole di scarico per agevolare la manutenzione ed il cambio olio
- Filtro acqua ispezionabile
- Soluzioni studiate per ottimizzare gli ingombri

General Features

- Two-wheel trolley with tyres, handle and anti-vibrating feet
- 3 Axial stainless steel pistons wobble-plate pump
- Automatic safety valve
- Pressure adjustment
- Thermal valve
- Built-in detergent suction
- Powered by Loncin petrol engine with low oil level sensor
- Inspectable oil levels
- Discharge plugs and discharge slots to make easy the maintenance and the oil change
- Inspectable water filter
- Space-saving solutions

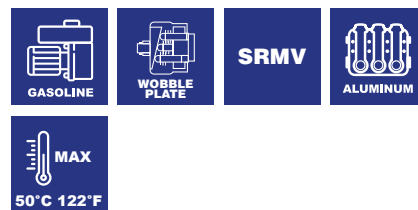

MOD	COD	MAX	MAX			Engine	Engine Type	kg NET	
		bar	psi	l/h	gph	rpm			
1435	26406	200	2900	660	174	3400	G200F	LONCIN	31,8

Accessori standard

Standard accessories



- 3600400 (low pressure) Nero/Black
- 3600930 (00035) Rosso/Red
- 3600940 (15035) Giallo/Yellow
- 3600960 (40035) Bianco/White





14 Series 1440

IDROPULTRICI CON MOTORE A SCOPPIO
petrol engine pressure washers

OLIGHTPRO



porta accessori
built-in accessories holder

filtro ingresso
acqua ispezionabile
inspectable water
intake filter

valvola termica
thermal valve

manico ergonomico
ergonomic handle

telaio in acciaio
verniciato
painted steel frame

battistrada in gomma
rubber wheels

Caratteristiche Generali

- Carrello completo di manico con due ruote e piedini antivibranti
- Pompa a 3 pistoni assiali comandati dal piattello oscillante
- Valvola di sicurezza automatica
- Valvola termica
- Aspirazione detergente incorporata
- Motorizzato Honda (benzina), con sensore mancanza olio
- Livelli olio ispezionabili
- Tappi ed asole di scarico per agevolare la manutenzione ed il cambio olio
- Filtro acqua ispezionabile
- Soluzioni studiate per ottimizzare gli ingombri

General Features

- Two-wheel trolley with tyres, handle and anti-vibrating feet
- 3 Axial stainless steel pistons wobble-plate pump
- Automatic safety valve
- Thermal valve
- Built-in detergent suction
- Powered by Honda petrol engine with low oil level sensor
- Inspectable oil levels
- Discharge plugs and discharge slots to make easy the maintenance and the oil change
- Inspectable water filter
- Space-saving solutions



MOD	COD	MAX	MAX			Engine	Engine Type	kg NET	
		bar	psi	l/h	gph	rpm			
1440	26216	200	2900	660	174	3400	GP160H	HONDA	31,4



Accessori standard Standard accessories



43471

3600650

43473
(8 m)



- 3600400 (low pressure) Nero/Black
- 3600930 (00035) Rosso/Red
- 3600940 (15035) Giallo/Yellow
- 3600960 (40035) Bianco/White



OLIGHTPRO



porta accessori
built-in accessories holder

manico ergonomico
ergonomic handle

filtro ingresso
acqua ispezionabile
inspectable water
intake filter

telaio in acciaio
verniciato
painted steel frame

valvola termica
thermal valve

battistrada in gomma
rubber wheels

**1445XE
TRADE
SELECTION**



Caratteristiche Generali

- Carrello completo di manico con due ruote e piedini antivibranti
- Pompa a 3 pistoni assiali comandati dal piattello oscillante
- Valvola di sicurezza automatica
- Regolazione della pressione
- Valvola termica
- Aspirazione detergente incorporata
- Motorizzato Rato (benzina), con sensore mancanza olio
- Livelli olio ispezionabili
- Tappi ed asole di scarico per agevolare la manutenzione ed il cambio olio
- Filtro acqua ispezionabile
- Soluzioni studiate per ottimizzare gli ingombri

General Features

- Two-wheel trolley with tyres, handle and anti-vibrating feet
- 3 Axial stainless steel pistons wobble-plate pump
- Automatic safety valve
- Pressure adjustment
- Thermal valve
- Built-in detergent suction
- Powered by Rato petrol engine with low oil level sensor
- Inspectable oil levels
- Discharge plugs and discharge slots to make easy the maintenance and the oil change
- Inspectable water filter
- Space-saving solutions



MOD	COD	MAX	MAX						KG NET
		bar	psi	l/h	gph	rpm	Engine	Engine Type	kg
1445	26407	220	3200	660	174	3400	EHR210	RATO	31,7
1445 XE	27856	220	3200	660	174	3400	EHR210	RATO	31,7



Accessori standard Standard accessories



43525 3600650 43473 (8 m)

41050 (1445 XE)

3600400 (low pressure) Nero/Black
3600930 (00035) Rosso/Red
3600940 (15035) Giallo/Yellow
3600960 (40035) Bianco/White



14 Series 1447

IDROPULTRICI CON MOTORE A SCOPPIO
petrol engine pressure washers

OLIGHTPRO



porta accessori
built-in accessories holder

filtro ingresso
acqua ispezionabile
inspectable water
intake filter

valvola termica
thermal valve

manico ergonomico
ergonomic handle

telaio in acciaio
verniciato
painted steel frame

battistrada in gomma
rubber wheels

Caratteristiche Generali

- Carrello completo di manico con due ruote e piedini antivibranti
- Pompa a 3 pistoni assiali comandati dal piattello oscillante
- Valvola di sicurezza automatica
- Regolazione della pressione
- Valvola termica
- Aspirazione detergente incorporata
- Motorizzato Rato (benzina), con sensore mancanza olio
- Livelli olio ispezionabili
- Tappi ed asole di scarico per agevolare la manutenzione ed il cambio olio
- Filtro acqua ispezionabile
- Soluzioni studiate per ottimizzare gli ingombri

General Features

- Two-wheel trolley with tyres, handle and anti-vibrating feet
- 3 Axial stainless steel pistons wobble-plate pump
- Automatic safety valve
- Pressure adjustment
- Thermal valve
- Built-in detergent suction
- Powered by Rato petrol engine with low oil level sensor
- Inspectable oil levels
- Discharge plugs and discharge slots to make easy the maintenance and the oil change
- Inspectable water filter
- Space-saving solutions



MOD	COD	MAX	MAX				Engine	Engine Type	kg
		bar	psi	l/h	gph	rpm			
1447	26578	220	3200	660	174	3400	EHR210	RATO	31,7

Accessori standard Standard accessories



43525

3600650

3780443
(10 m)



- 3600400 (low pressure) Nero/Black
- 3600930 (00035) Rosso/Red
- 3600940 (15035) Giallo/Yellow
- 3600960 (40035) Bianco/White



HEAVYPRO



Caratteristiche Generali

- Carrello completo di manico con due ruote e piedini antivibranti
- Pompa a pistoni con sistema biella-manovella ad elevate prestazioni
- Valvola di sicurezza automatica
- Regolazione della pressione
- Valvola termica
- Aspirazione detergente incorporata
- Motorizzato Honda (benzina), con sensore mancanza olio
- Livelli olio ispezionabili
- Tappi ed asole di scarico per agevolare la manutenzione ed il cambio olio
- Filtro acqua ispezionabile
- Soluzioni studiate per ottimizzare gli ingombri

General Features

- Two-wheel trolley with tyres, handle and anti-vibrating feet
- High performance piston pump with connecting rod system
- Automatic safety valve
- Pressure adjustment
- Thermal valve
- Built-in detergent suction
- Powered by Honda petrol engine with low oil level sensor
- Inspectable oil levels
- Discharge plugs and discharge slots to make easy the maintenance and the oil change
- Inspectable water filter
- Space-saving solutions

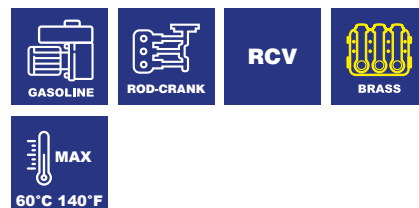

MOD	COD	MAX	MAX			Engine	Engine Type	kg NET	
		bar	psi	l/h	gph	rpm			
1450	26217	220	3200	720	190	3400	GP200H	HONDA	34,7

Accessori standard

Standard accessories

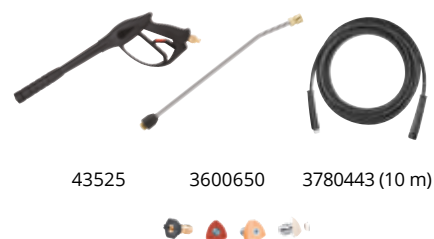

- 3600400 (low pressure) Nero/Black
- 3600930 (00035) Rosso/Red
- 3600940 (15035) Giallo/Yellow
- 3600960 (40035) Bianco/White



HEAVYPRO

**1475XE
TRADE
SELECTION**



Caratteristiche Generali

- Carrello completo di manico con due ruote pneumatiche gonfiabili e piedini antivibranti
- Pompa a pistoni con sistema biella-manovella ad elevate prestazioni
- Valvola di by-pass automatica
- Regolazione della pressione
- Valvola termica
- Aspirazione detergente incorporata
- Motorizzato Honda/Loncin (benzina), con sensore mancanza olio
- Livelli olio ispezionabili
- Tappi ed asole di scarico per agevolare la manutenzione ed il cambio olio
- Filtro acqua ispezionabile
- Soluzioni studiate per ottimizzare gli ingombri

General Features

- Two-wheel trolley with handle, inflatable pneumatic wheels and anti-vibrating feet
- High performance piston pump with connecting rod system
- Automatic by-pass valve
- Pressure adjustment
- Thermal valve
- Built-in detergent suction
- Powered by Honda/Loncin petrol engine with low oil level sensor
- Inspectable oil levels
- Discharge plugs and discharge slots to make easy the maintenance and the oil change
- Inspectable water filter
- Space-saving solutions



MOD	COD	MAX	MAX			Engine	Engine Type	kg NET	
		bar	psi	l/h	gph	rpm			
1460	26218	270	4000	900	238	3400	GX270	HONDA	50,9
1475	26325	280	4060	960	254	3400	G390F	LONCIN	58,4
1475 XE	27857	280	4060	960	254	3400	G390F	LONCIN	58,4
1480	26219	280	4060	960	254	3400	GX390	HONDA	57,1

Accessori standard Standard accessories

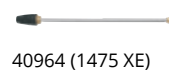

- 1460 1475.1480
 3600400 (low p.) 3600400 (low p.) Nero/Black
 3600930 (00035) 3600350 (0004) Rosso/Red
 3600940 (15035) 3600360 (1504) Giallo/Yellow
 3600960 (40035) 3600380 (4004) Bianco/White





HEAVYPRO



Caratteristiche Generali

- Carrello completo di manico con due ruote pneumatiche gonfiabili e piedini antivibranti
- Pompa a pistoni con sistema biella-manovella ad elevate prestazioni
- Valvola di by-pass automatica
- Regolazione della pressione
- Valvola termica / Riduttore di giri
- Aspirazione detergente incorporata
- Motorizzato Honda (benzina), con sensore mancanza olio
- Livelli olio ispezionabili, per pompa e riduttore
- Tappi ed asole di scarico per agevolare la manutenzione ed il cambio olio
- Filtro acqua ispezionabile
- Soluzioni studiate per ottimizzare gli ingombri

General Features

- Two-wheel trolley with inflatable tyres, handle and damper feet inflatable pneumatic wheels and anti-vibrating feet
- High performance piston pump with connecting rod system
- Automatic by-pass valve
- Pressure adjustment
- Thermal valve / Gear box
- Built-in detergent suction
- Powered by Honda petrol engine with low oil level sensor
- Inspectable oil levels for pump and gear box
- Discharge plugs and discharge slots to make easy the maintenance and the oil change
- Inspectable water filter
- Space-saving solutions



MOD	COD								
		MAX	MAX		NET				
		bar	psi	l/h	gph	rpm	Engine	Engine Type	kg
1490	26408	280	4060	960	254	1750	GX390	HONDA	64

Accessori standard

Standard accessories



- 3600400 (low pressure) Nero/Black
- 3600350 (0004) Rosso/Red
- 3600360 (1504) Giallo/Yellow
- 3600380 (4004) Bianco/White



ACCESSORI

Accessories



			6 Series										9 Series			
			611	613	614	613K	614K	630	630K	670	671	680	680K	930	960	980
Pistola Trigger gun		43471		S	S	S	S	S	S	S						
		46880	S									S	S	S	S	
		47039													S	
Estensione lancia Lance extension		40039 (51 cm)						S								
		46056 (49 cm)							S							
		43472 (49 cm)		S		S										
		41806 (49 cm)			S		S									
		41929 (47 cm)												S		
		46818 (47 cm)	S													
		43954 (47 cm)								S						
		43955 (47 cm)									S					
		46816 (47 cm)										S	S			
		46221 (56 cm)													S	S
		3086 (15045)													S	S
	Lancia getto rotante Rotary lance		3157 (1508)												O	
		40638 (56 cm)	O					O	O			O	O			
		40167 (56 cm)		O		O										
		40169 (56 cm)									O					
Lancia getto rotante PRO Rotary lance PRO		40151 (56 cm)			O		O			O						
		40968 (56 cm)												O		
Tubo AP HP hose		40803 (56 cm)												O	O	
		1271351 (10 m)						S	S							
Tubo armato AP Reinforced HP hose		3960920 (8m)	S									S	S			
		47024 (8 m)		S	S											
		43743 (8 m)							S	S						
		3780441 (10 m)				S	S									
		3960970 (10 m)												S		
		3961050 (10 m)													S	S
Prolunga tubo armato Reinforced extension hose		40106 incluso nel kit / included in kit	O	O	O	O	O	O	O	O	O	O	O	O	O	
		1123890														
Kit schiumogeno alta pressione High pressure foam lance bottle		41552	O	O	O	O	O	O	O	O	O	O	O	O	O	
Kit HYG HYG kit		46742	O	O	O	O	O			O	O					

Legenda: "S" Accessorio di serie - "O" Accessorio opzionale
 "S" On board accessory - "O" Optional accessory

			6 Series										9 Series				
			611	613	614	613K	614K	630	630K	670	671	680	680K	930	960	980	
Kit pulizia tubazioni <i>Pipe drain kit</i>		46364 (8 m)	<input type="checkbox"/>	<input type="checkbox"/>	<input type="checkbox"/>	<input type="checkbox"/>	<input type="checkbox"/>	<input type="checkbox"/>	<input type="checkbox"/>	<input type="checkbox"/>	<input type="checkbox"/>	<input type="checkbox"/>	<input type="checkbox"/>	<input type="checkbox"/>	<input type="checkbox"/>	<input type="checkbox"/>	
		46366 (16 m)	<input type="checkbox"/>	<input type="checkbox"/>	<input type="checkbox"/>	<input type="checkbox"/>	<input type="checkbox"/>	<input type="checkbox"/>	<input type="checkbox"/>	<input type="checkbox"/>	<input type="checkbox"/>	<input type="checkbox"/>	<input type="checkbox"/>	<input type="checkbox"/>	<input type="checkbox"/>	<input type="checkbox"/>	<input type="checkbox"/>
Spazzola fissa <i>Fixed brush</i>		41577	<input type="checkbox"/>	<input type="checkbox"/>	<input type="checkbox"/>	<input type="checkbox"/>	<input type="checkbox"/>	<input type="checkbox"/>	<input type="checkbox"/>	<input type="checkbox"/>	<input type="checkbox"/>	<input type="checkbox"/>					
Spazzola rotante <i>Rotary brush</i>		41578	<input type="checkbox"/>	<input type="checkbox"/>	<input type="checkbox"/>	<input type="checkbox"/>	<input type="checkbox"/>	<input type="checkbox"/>	<input type="checkbox"/>	<input type="checkbox"/>	<input type="checkbox"/>	<input type="checkbox"/>					
Spazzola rotante PRO <i>Rotary brush PRO</i>		46370											<input type="checkbox"/>	<input type="checkbox"/>	<input type="checkbox"/>		
Lavapavimenti d. 30 cm <i>Patio cleaner d. 30 cm</i>		41687	<input type="checkbox"/>	<input type="checkbox"/>	<input type="checkbox"/>	<input type="checkbox"/>	<input type="checkbox"/>	<input type="checkbox"/>	<input type="checkbox"/>	<input type="checkbox"/>	<input type="checkbox"/>	<input type="checkbox"/>					
		46359	<input type="checkbox"/>	<input type="checkbox"/>	<input type="checkbox"/>	<input type="checkbox"/>	<input type="checkbox"/>	<input type="checkbox"/>	<input type="checkbox"/>	<input type="checkbox"/>	<input type="checkbox"/>	<input type="checkbox"/>	<input type="checkbox"/>				
Lavapavimenti PRO con regolazione pressione <i>Patio cleaner w. pressure adjustment</i>		46368	<input type="checkbox"/>	<input type="checkbox"/>	<input type="checkbox"/>	<input type="checkbox"/>	<input type="checkbox"/>		<input type="checkbox"/>	<input type="checkbox"/>	<input type="checkbox"/>	<input type="checkbox"/>					
		46369						<input type="checkbox"/>	<input type="checkbox"/>					<input type="checkbox"/>	<input type="checkbox"/>	<input type="checkbox"/>	
Kit lancia sabbiante PRO <i>Sandblasting lance kit PRO</i>		41591 (50 cm)	<input type="checkbox"/>	<input type="checkbox"/>	<input type="checkbox"/>	<input type="checkbox"/>	<input type="checkbox"/>			<input type="checkbox"/>	<input type="checkbox"/>						
		41762 (50 cm)						<input type="checkbox"/>	<input type="checkbox"/>			<input type="checkbox"/>	<input type="checkbox"/>	<input type="checkbox"/>	<input type="checkbox"/>	<input type="checkbox"/>	<input type="checkbox"/>
Sabbia calibrata e filtrata <i>Calibrated, filtered sand</i>		3207 (5 Kg)	<input type="checkbox"/>	<input type="checkbox"/>	<input type="checkbox"/>	<input type="checkbox"/>	<input type="checkbox"/>	<input type="checkbox"/>	<input type="checkbox"/>	<input type="checkbox"/>	<input type="checkbox"/>	<input type="checkbox"/>	<input type="checkbox"/>	<input type="checkbox"/>	<input type="checkbox"/>	<input type="checkbox"/>	
		41770 (25 Kg)	<input type="checkbox"/>	<input type="checkbox"/>	<input type="checkbox"/>	<input type="checkbox"/>	<input type="checkbox"/>	<input type="checkbox"/>	<input type="checkbox"/>	<input type="checkbox"/>	<input type="checkbox"/>	<input type="checkbox"/>	<input type="checkbox"/>	<input type="checkbox"/>	<input type="checkbox"/>	<input type="checkbox"/>	<input type="checkbox"/>
Kit adescamento <i>Self priming kit</i>		41592	<input type="checkbox"/>	<input type="checkbox"/>	<input type="checkbox"/>	<input type="checkbox"/>	<input type="checkbox"/>	<input type="checkbox"/>	<input type="checkbox"/>	<input type="checkbox"/>	<input type="checkbox"/>	<input type="checkbox"/>	<input type="checkbox"/>	<input type="checkbox"/>	<input type="checkbox"/>	<input type="checkbox"/>	
		47332	<input type="checkbox"/>	<input type="checkbox"/>	<input type="checkbox"/>	<input type="checkbox"/>	<input type="checkbox"/>	<input type="checkbox"/>	<input type="checkbox"/>	<input type="checkbox"/>	<input type="checkbox"/>	<input type="checkbox"/>	<input type="checkbox"/>				
		47333												<input type="checkbox"/>	<input type="checkbox"/>	<input type="checkbox"/>	
Kit lancia sottoscocca <i>Underbody lance kit</i>		41590 (1503-80cm)		<input type="checkbox"/>	<input type="checkbox"/>	<input type="checkbox"/>	<input type="checkbox"/>			<input type="checkbox"/>	<input type="checkbox"/>	<input type="checkbox"/>	<input type="checkbox"/>				
		41751 (1504-80 cm)												<input type="checkbox"/>			
		43372 (15045-80cm)						<input type="checkbox"/>	<input type="checkbox"/>						<input type="checkbox"/>	<input type="checkbox"/>	
Lancia senza ugello <i>Lance without nozzle</i>		40652 (90 cm)	<input type="checkbox"/>	<input type="checkbox"/>	<input type="checkbox"/>	<input type="checkbox"/>	<input type="checkbox"/>	<input type="checkbox"/>	<input type="checkbox"/>	<input type="checkbox"/>	<input type="checkbox"/>	<input type="checkbox"/>	<input type="checkbox"/>	<input type="checkbox"/>	<input type="checkbox"/>	<input type="checkbox"/>	
		40653 (120 cm)	<input type="checkbox"/>	<input type="checkbox"/>	<input type="checkbox"/>	<input type="checkbox"/>	<input type="checkbox"/>	<input type="checkbox"/>	<input type="checkbox"/>	<input type="checkbox"/>	<input type="checkbox"/>	<input type="checkbox"/>	<input type="checkbox"/>	<input type="checkbox"/>	<input type="checkbox"/>	<input type="checkbox"/>	
		40654 (150 cm)	<input type="checkbox"/>	<input type="checkbox"/>	<input type="checkbox"/>	<input type="checkbox"/>	<input type="checkbox"/>	<input type="checkbox"/>	<input type="checkbox"/>	<input type="checkbox"/>	<input type="checkbox"/>	<input type="checkbox"/>	<input type="checkbox"/>	<input type="checkbox"/>	<input type="checkbox"/>	<input type="checkbox"/>	
		40694 (170 cm)	<input type="checkbox"/>	<input type="checkbox"/>	<input type="checkbox"/>	<input type="checkbox"/>	<input type="checkbox"/>	<input type="checkbox"/>	<input type="checkbox"/>	<input type="checkbox"/>	<input type="checkbox"/>	<input type="checkbox"/>	<input type="checkbox"/>	<input type="checkbox"/>	<input type="checkbox"/>	<input type="checkbox"/>	
		40695 (200 cm)	<input type="checkbox"/>	<input type="checkbox"/>	<input type="checkbox"/>	<input type="checkbox"/>	<input type="checkbox"/>	<input type="checkbox"/>	<input type="checkbox"/>	<input type="checkbox"/>	<input type="checkbox"/>	<input type="checkbox"/>	<input type="checkbox"/>	<input type="checkbox"/>	<input type="checkbox"/>	<input type="checkbox"/>	

			6 Series										9 Series			
			611	613	614	613K	614K	630	630K	670	671	680	680K	930	960	980
Lancia doppia <i>Double lance</i>		3160620 (66 cm)												<input type="radio"/>	<input type="radio"/>	<input type="radio"/>
Ugello bassa pressione <i>Low pressure nozzle</i>		3251 (2525)												<input type="radio"/>	<input type="radio"/>	<input type="radio"/>
Testina doppio ugello <i>Roller nozzle</i>		3025												<input type="radio"/>	<input type="radio"/>	<input type="radio"/>
Kit adattatori <i>Adapters kit</i>		41758		<input type="radio"/>	<input type="radio"/>	<input type="radio"/>	<input type="radio"/>	<input type="radio"/>	<input type="radio"/>	<input type="radio"/>	<input type="radio"/>	<input type="radio"/>				
Filtro acqua ispezionabile <i>Inspectable water filter</i>		41663 (3 pcs)		<input type="radio"/>	<input type="radio"/>	<input type="radio"/>	<input type="radio"/>	<input type="radio"/>	<input type="radio"/>	<input type="radio"/>	<input type="radio"/>	<input type="radio"/>	<input type="radio"/>	<input type="radio"/>	<input type="radio"/>	<input type="radio"/>
Kit filtro acqua <i>Water filter kit</i>		41593	<input type="radio"/>	<input type="radio"/>	<input type="radio"/>	<input type="radio"/>	<input type="radio"/>	<input type="radio"/>	<input type="radio"/>	<input type="radio"/>	<input type="radio"/>	<input type="radio"/>	<input type="radio"/>	<input type="radio"/>	<input type="radio"/>	<input type="radio"/>
Kit attacco rapido <i>Click fast kit</i>		41580	<input type="radio"/>	<input type="radio"/>	<input type="radio"/>	<input type="radio"/>	<input type="radio"/>	<input type="radio"/>	<input type="radio"/>	<input type="radio"/>	<input type="radio"/>	<input type="radio"/>	<input type="radio"/>	<input type="radio"/>	<input type="radio"/>	<input type="radio"/>
Kit attacco rapido ottone <i>Brass click fast kit</i>		40439	<input type="radio"/>	<input type="radio"/>	<input type="radio"/>	<input type="radio"/>	<input type="radio"/>		<input type="radio"/>	<input type="radio"/>	<input type="radio"/>	<input type="radio"/>	<input type="radio"/>	<input type="radio"/>	<input type="radio"/>	<input type="radio"/>
		40440						<input type="radio"/>	<input type="radio"/>							
Kit RLW senza tubo <i>Hose reel kit without hose</i>		41738	<input type="radio"/>	<input type="radio"/>	<input type="radio"/>	<input type="radio"/>	<input type="radio"/>	<input type="radio"/>	<input type="radio"/>	<input type="radio"/>	<input type="radio"/>	<input type="radio"/>				
		46904												<input type="radio"/>	<input type="radio"/>	<input type="radio"/>
Kit RLW con 15 m tubo AP <i>with HP hose 15 m</i>		41879	<input type="radio"/>	<input type="radio"/>	<input type="radio"/>	<input type="radio"/>	<input type="radio"/>	<input type="radio"/>	<input type="radio"/>	<input type="radio"/>	<input type="radio"/>	<input type="radio"/>				
Kit carrello <i>Trolley kit</i>		41869	<input type="radio"/>	<input type="radio"/>	<input type="radio"/>						<input type="radio"/>					
		43972						<input type="radio"/>		<input type="radio"/>	<input type="radio"/>					
Kit avvolgitubo a muro senza tubo <i>Wall mounted hose reel without hose kit</i>		41739	<input type="radio"/>	<input type="radio"/>	<input type="radio"/>	<input type="radio"/>	<input type="radio"/>		<input type="radio"/>		<input type="radio"/>	<input type="radio"/>				
Kit avvolgitubo a muro con tubo 15 m <i>Wall mounted hose reel with hose 15 m</i>		41880	<input type="radio"/>	<input type="radio"/>	<input type="radio"/>	<input type="radio"/>	<input type="radio"/>		<input type="radio"/>		<input type="radio"/>	<input type="radio"/>				











Legenda: "S" Accessorio di serie - "O" Accessorio opzionale
"S" On board accessory - "O" Optional accessory

*in abbinamento kit carrello 41869|43972
**in combination trolley kit 41869|43972*

10·11·14 Series

ACCESSORI
accessories



		10 Series											11 Series	14 Series																
		1003K	1005K	1001	1003	1003RLW	1003XE	1006XE	1007	1007RLW	1007XE	1009	1015	1018	1018H	1120	1415	1425	1435	1440	1445	1445XE	1447	1450	1460	1475	1475XE	1480	1490	
Pistola Trigger gun		43471	S	S	S	S	S										S	S	S											
		46880		S																										
		47039						S	S	S	S	S																		
		41089											S	S	S															
		41847															S													
		46328																S												
Lancia getto regolabile Lance with adjustable spray nozzle		43524																						S	S	S	S	S		
		43525																			S	S	S	S						
Lancia con testina alta/ bassa senza ugello Lance with high/low pressure head w/out nozzle		43472																												
		41747	S																											
Lancia con testina fissa senza ugello Lance with fixed head w/ out nozzle		41748		S																										
		46221	O	O	O	O	O	O	O	O	O	S	S	S		S	O	O	O	O	O	O	O	O	O	O	O	O	O	
Prolunga lancia Lance Extension		50690																												
		3600650		S	S	S	S	S	S	S	S							S	S	S	S	S	S	S	S	S	S	S	S	
Testina getto regolabile Adjustable jet nozzle		46332															S													
		4381820																S												
Ugelli Wash nozzles 1/4 MEG ***		3104 (1503)																O			O	O								
		3195 (15035)																		O	O			O	O	O				
		3082 (1504)	O	O																							O	O	O	O
		3086 (15045)							O	O						S														
		3083 (1505)						O					S	S																
		3095 (15055)		O																										
Ugelli Wash nozzles 1/4 MEG ***		3090 (2507)									S																			
		3250 (15075)								O																				
		3089 (2506)													S															

(***) Per modelli/For models: 1003K, 1005K, 1001, 1003, 1006, 1007, 1009, 1440, 1435, 1445, 1447, 1450, 1460, 1475, 1480, 1490, 1003XE, 1007XE, 1007NXE, 1445XE, 1475XE: occorre comprare la lancia cod. 46221 per montare gli ugelli tipo MEG/ Buy even lance code 46221 to use MEG type nozzles













		10 Series											11 Series	14 Series																	
		1003K	1005K	1001	1003	1003RLW	1003XE	1006XE	1007	1007RLW	1007XE	1009	1015	1018	1018H	1120	1415	1425	1435	1440	1445	1445XE	1447	1450	1460	1475	1475XE	1480	1490		
Ugelli Nozzles		3600400 (bassa p./ low p.)		S	S	S	S	S	S	S	S							S	S	S	S	S		S	S	S	S	S	S		
		3600440(0003)		S														S			S	S									
		3600350(0004)				S	S	S																			S	S	S	S	
		3600480(00045)						S	S	S																					
		3600680(00075)									S																				
		3600930(00035)																		S	S			S	S						
		3600450(1503)		S															S			S	S								
		3600360(1504)				S	S	S																			S	S	S	S	
		3600490(15045)							S	S	S																				
		3600690(15075)									S																				
		3600940(15035)																		S	S			S	S						
		3600460(2503)		S																											
		3600370(2504)				S	S	S																							
		3600500(25045)							S	S	S																				
		3600700(25075)									S																				
		3600470(4003)		S															S		S	S									
		3600380(4004)				S	S	S																			S	S	S	S	
		3600510(40045)							S	S	S																				
		3600710(40075)									S																				
		3600960(40035)																		S	S			S	S						
Lancia getto rotante PRO Rotary lance PRO		41050 (56 cm)		O														O			O	S									
		40968 (56 cm)	O		O	O														O	O			O	O						
		40964 (56 cm)																								O	S	O	O		
		40803 (56 cm)						O	O	O	S		O	O	O									O	O						
		40966 (56 cm)		O																											
		40965 (56 cm)															O														
		40969 (56 cm)									O																				
		46635 (56 cm)					S																								
Testina getto rotante Rotary jet nozzle		41565															O														

Legenda: "S" Accessorio di serie - "O" Accessorio opzionale
"S" On board accessory - "O" Optional accessory

(***) Per modelli/For models: 1003K, 1005K, 1001, 1003, 1006, 1007, 1009, 1440, 1435, 1445, 1447, 1450, 1460, 1475, 1480, 1490, 1003XE, 1007XE, 1007NXE, 1445XE, 1475XE: occorre comprare la lancia cod. 46221 per montare gli ugelli tipo MEG/ Buy even lance code 46221 to use MEG type nozzles



		10 Series										11 Series	14 Series																
		1003K	1005K	1001	1003	1003RLW	1003XE	1006XE	1007	1007RLW	1007XE	1009	1015	1018	1018H	1120	1415	1425	1435	1440	1445	1445XE	1447	1450	1460	1475	1475XE	1480	1490
Tubo AP Hose HP		4000870 (5 m)															S												
		3780492 (8 m)																S											
		43473 (8 m) Reinforced	O																S	S	S	S							
		3780441 (10 m) Reinforced	S																										
		3600620 (10 m) Reinforced		S																									
		3780443 (10 m) Reinforced																						S	S				
		1271960 (10 m) Reinforced				S	S	S																					
		3961050 (10 m) Reinforced	S			S	S	S	S	S																			
		3600970 (15 m) Reinforced							S	S																			
		2500380 (15 m) Reinforced																											
		1700981 (10 m) Reinforced																							S	S	S	S	S
		3160170 (10 m) Reinforced									S	S																	
		50247 (10 m) Reinforced															S												
		50258 (10 m) Reinforced Non marking															O												
		3260590 (10 m) Reinforced Non marking										O	O	S															
Tubo aspirazione 100°C Suction hose 100°C		3260600 (70 cm)														S													
Prolunga tubo Extension hose		41585 (8 m)															O												
Prolunga tubo armato Reinforced extension hose		46493 (10 m)																						O	O	O	O	O	
		40641 (15 m)	O	O	O	O	O	O										O	O	O									
		46849 (20m)																											
		40106 (15 m)	O						O	O	O	O	O	O		O						O	O	O	O				
		46850 (15m)																						O	O	O	O	O	

		10 Series										11 Series	14 Series															
		1003K	1005K	1001	1003	1003RLW	1003XE	1006XE	1007	1007RLW	1007XE	1009	1015	1018	1018H	1120	1415	1425	1435	1440	1445	1445XE	1447	1450	1460	1475	1475XE	1480
Kit schiumogeno alta pressione <i>High pressure foam lance bottle</i>		41552	O	O	O	O	O	O	O	O	O	O	O	O	O	O	O	O	O	O	O	O	O	O	O	O	O	O
	46364 (8 m)	O	O	O	O	O	O	O	O	O		O				O	O	O	O	O	O	O	O	O	O	O	O	O
Kit pulizia tubazioni <i>Pipe drain kit</i>		46366 (8 m)	O	O	O	O	O	O	O	O		O				O	O	O	O	O	O	O	O	O	O	O	O	O
	46366 (16 m)	O	O	O	O	O	O	O	O	O		O				O	O	O	O	O	O	O	O	O	O	O	O	O
	46367 (16 m)											O			O													
	1272520 (8 m)														O													
	1272530 (16 m)														O													
Spazzola fissa <i>Fixed brush</i>		41577	O		O	O	O	O								O	O	O	O	O	O	O	O					
Spazzola rotante <i>Rotary brush</i>		41578		O												O	O	O	O									
Spazzola rotante PRO <i>Rotary brush PRO</i>		46370	O		O	O	O	O	O	O		O	O		O				O	O	O	O	O	O	O	O	O	
	46371											O																
Lavapavimenti con serbatoio detergente d. 30 cm <i>Patio cleaner with detergent tank d. 30 cm</i>		41687		O																								
Lavapavimenti d. 30 cm <i>Patio cleaner d. 30 cm</i>		46359		O													O											
Lavapavimenti PRO con regolazione pressione <i>Patio cleaner PRO with pressure adjustment</i>		46368		O																								
	46369	O	O		O	O	O	O	O	O		O	O					O	O	O	O	O	O	O	O	O	O	
Kit lancia sabbiante <i>Sand blasting lance</i>		41760														O												
Kit lancia sabbiante PRO <i>Sand blasting lance PRO</i>		41591		O																								
	41762	O	O		O	O	O	O				O	O					O	O	O	O	O	O	O	O	O	O	
	41763						O			O	O				O													
Sabbia calibrata e filtrata <i>Calibrated filtered sand</i>		3207 (5 kg)	O	O	O	O	O	O	O	O	O	O	O	O	O	O	O	O	O	O	O	O	O	O	O	O	O	
		41770 (25 kg)	O	O	O	O	O	O	O	O	O	O	O	O	O	O	O	O	O	O	O	O	O	O	O	O	O	
Kit aspirazione acqua <i>Water suction kit</i>		41592	O	O	O	O	O	O	O	O		O	O				O	O	O	O	O	O	O	O	O	O	O	

Legenda: "S" Accessorio di serie - "O" Accessorio opzionale
"S" On board accessory - "O" Optional accessory



		10 Series												11 Series	14 Series																
		1003K	1005K	1001	1003	1003RLW	1003XE	1006XE	1007	1007RLW	1007XE	1009	1015	1018	1018H	1120	1415	1425	1435	1440	1445	1445XE	1447	1450	1460	1475	1475XE	1480	1490		
Kit tubo aspirazione <i>Hoose suction kit</i>		47333	○	○	○	○	○	○	○	○	○	○	○	○	○	○															
Adattatore snodato per testine <i>Adjustable head nozzle adptor</i>		46009														○															
Kit lancia sottoscocca <i>Underbody lance</i>		41590 (1503)															○				○	○									
		41752 (15035)																	○	○				○	○						
		41751 (1504)	○		○	○	○	○																			○	○	○	○	
		46372 (15045)						○	○	○	○				○																
		41753 (1505)												○																	
Lancia senza ugello <i>Lance w/out nozzle</i>		46373 (1506)		○																											
		41754 (1508)											○																		
		40652	○	○	○	○	○	○	○	○	○	○	○	○	○	○	○	○	○	○	○	○	○	○	○	○	○	○	○	○	○
		40653 (120 cm)	○	○	○	○	○	○	○	○	○	○	○	○	○	○	○	○	○	○	○	○	○	○	○	○	○	○	○	○	○
40654 (150 cm)	○	○	○	○	○	○	○	○	○	○	○	○	○	○	○	○	○	○	○	○	○	○	○	○	○	○	○	○	○	○	
40694 (170 cm)	○	○	○	○	○	○	○	○	○	○	○	○	○	○	○	○	○	○	○	○	○	○	○	○	○	○	○	○	○	○	
40695 (200 cm)	○	○	○	○	○	○	○	○	○	○	○	○	○	○	○	○	○	○	○	○	○	○	○	○	○	○	○	○	○	○	
Lancia doppia senza ugelli <i>Double lance without nozzles</i>		3160620 (66 cm)	○		○	○	○	○	○	○	○	○	○	○	○	○	○	○	○	○	○	○	○	○	○	○	○	○	○	○	
Ugello bassa pressione <i>Low pressure nozzle</i>		3251 (2525)	○		○	○	○	○	○	○	○	○	○	○	○	○	○	○	○	○	○	○	○	○	○	○	○	○	○	○	
Testina doppio ugello <i>Roller nozzle</i>		3025	○		○	○	○	○	○	○	○	○	○	○	○	○	○	○	○	○	○	○	○	○	○	○	○	○	○	○	
Kit adattatori <i>Adaptors kit</i>		41758	○	○	○	○	○										○	○	○	○	○										
Filtro acqua ispezionabile <i>Inspectable water filter</i>		41663 (3 pcs)	S	S	S	S	S	S	S	S	S	○	○	○		○	S	S	S	S	S	S	S	S	S	S	S	S	S		
Kit filtro acqua <i>Water filter kit</i>		41593	○	○	○	○	○	○	○	○	○	○	○	○		○	○	○	○	○	○	○	○	○	○	○	○	○	○	○	
Kit attacco rapido <i>Click fast kit</i>		41580	○	○	○	○	○	○	○	○	○	○	○	○		○	○	○	○	○	○	○	○	○	○	○	○	○	○	○	
Kit attacco rapido in ottone <i>Brass click fast kit</i>		40439	○	○	○	○	○	○	○	○	○	○	○	○		○	○	○	○	○	○	○	○	○	○	○	○	○	○	○	
Kit RLW con tubo <i>Hose reel kit with hose</i>		41766 (10 m)	○	○																											
Kit RLW senza tubo <i>Hose reel kit w/out hose</i>		42658		○																											
		42509			○	○	○	○																							
		42659						○		○																					
		51290												○																	
		50272													○	○															
50273															○																

PRO HOT

Per utilizzi specifici dove l'acqua calda è un must, le idropulitrici Annovi Reverberi con caldaia, soddisfano in pieno le esigenze più estreme di sanificazione e rimozione dello sporco, grazie a prestazioni top di categoria, alla loro tecnologia Made in Italy ed alla loro praticità d'utilizzo.

For specific uses where hot water is a must, Annovi Reverberi high pressure washers with boiler meet the most extreme sanitisation and dirt removal requirements in full, thanks to class-topping performances, Italian technology and very convenient use.



Applicazioni ed indicatori di prestazioni PRO HOT

PRO HOT performance Indicators & Applications

BLUE CLEAN PRO LEVEL

○ LIGHTPRO

Fascia di idropulitrici progettate per utilizzatori esperti che hanno necessità di eseguire lavori di pulizia abbastanza frequenti e che richiedono una abbondante riserva di potenza.

High pressure washer category designed for skilled users tackling cleaning quite frequent jobs operations which need plenty of power in reserve.

● HEAVYPRO

Fascia di idropulitrici progettate per professionisti che hanno necessità di eseguire lavori di pulizia molto frequenti che richiedono le massime prestazioni.

High pressure cleaner category designed for professionals, dealing with cleaning high frequent jobs that need the very highest-performing appliances.

BLUE CLEAN FACTOR



La combinazione ideale tra prestazioni tecniche e configurazione commerciale per poter risolvere al meglio le tue esigenze di pulizia. I prodotti che hanno il BLUE FACTOR sono i migliori, all'interno della loro categoria, per poter pulente, facilità d'utilizzo e prestazioni tecniche. Il mix perfetto per ogni tua esigenza di pulizia.

The ideal combination of technical features and commercial configuration, to deliver the best solution to your cleaning needs. Products with the BLUE FACTOR are best-in-class in cleaning power, ease of use and technical performances. The perfect mix for all your cleaning requirements.

PROFESSIONAL APPLICATIONS

	edilizia construction
	agricoltura zootecnica agriculture zootechny
	artigianato crafts
	car wash
	automotive

Gamma di idropultrici pensate per le sollecitazioni di impiego più prestazionali. Ideali per il settore edile, agricolo e le municipalizzate – coniugano perfettamente il sapere costruttivo Annovi Reverberi con la praticità di un design semplice ma estremamente funzionale.

Range of high pressure washers designed to withstand the most high-performing applications. Ideal for the construction industry, farming and utility companies, they are the ideal blend of Annovi Reverberi's construction know-how and the convenience of simple, stylish, highly functional design.

						
25 Series						
2591		●	●			
35 Series						
3590		●	●			
45 Series						
4590		●	●	●		
56 Series						
5670		●	●	●		
58 Series						
5850		●	●	●		
5870		●	●	●		
66 Series						
6640N		●	●	●		
6670N		●	●	●		
69 Series						
6950		●	●	●	●	●
6970N		●	●	●	●	●
78 Series						
7850N		●	●	●	●	●
7870N		●	●	●	●	●
88 Series						
8840		●	●	●	●	●
8860		●	●	●	●	●
8880		●	●	●	●	●
13 Series						
1310		●	●	●	●	●
1320		●	●	●	●	●
1325		●	●	●	●	●
1380		●	●	●	●	●

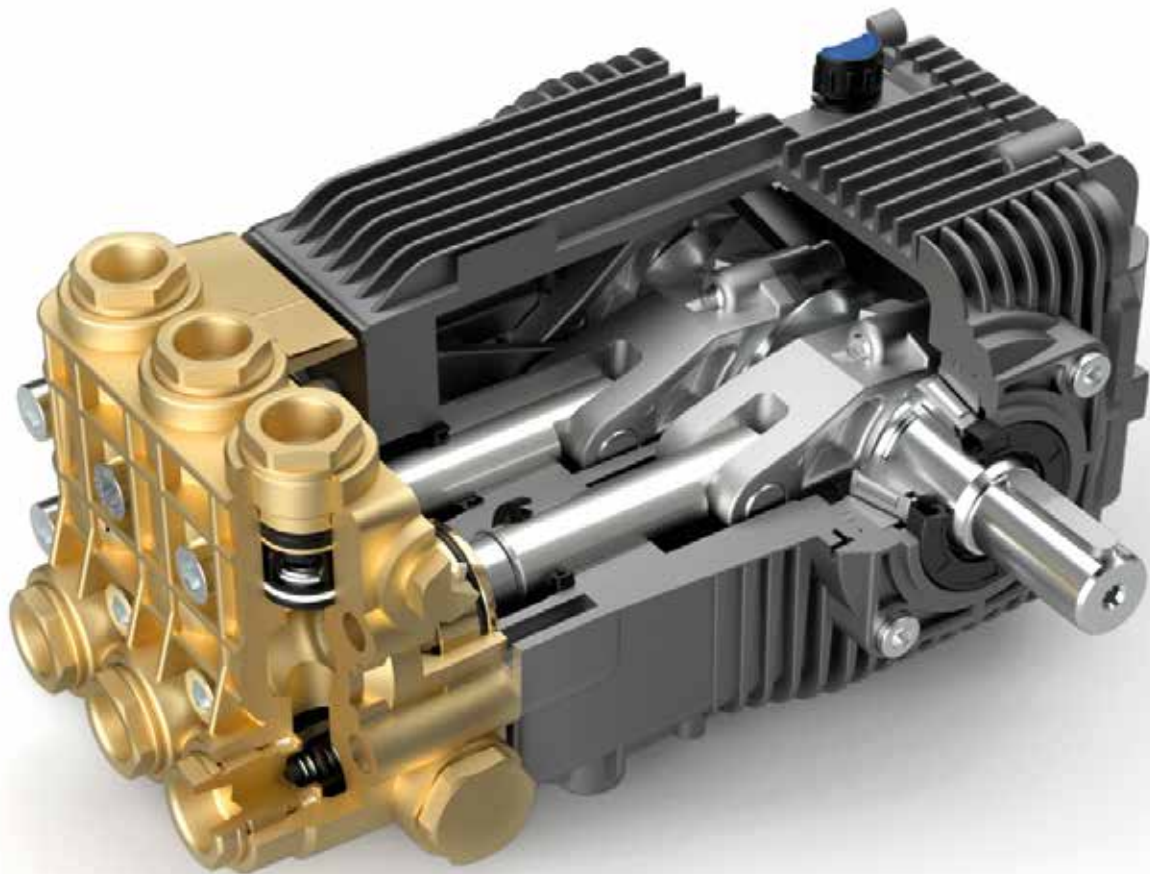

Pompa con sistema biella-manovella per utilizzo in orizzontale. Corpo e coperchi laterali con livello olio.
Bielle in lega zinco-alluminio pressofuso.
Testa in ottone forgiato con disegno ad alta resistenza.
Pistoni in ceramica.
Sistema di tenuta a doppia guarnizione.
I componenti interni sono tutti di dimensioni maggiorate in grado di garantire una buona affidabilità e resistenza nel tempo.

*Wobble plate pump for orizontal use.
Crankcase and side covers with oil level.
Connecting rods in die-cast zinc-aluminium alloy.
High strength forged brass head with design.
Ceramic plungers.
Double seal sealing system.
The internal components are all oversized to ensure good reliability and durability.*

HRM

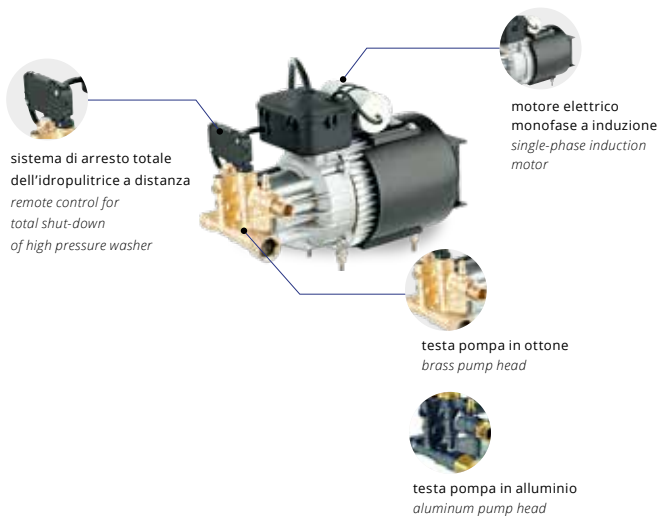

- Pompa a 3 pistoni assiali comandati dal piattello oscillante, testa ottone
- Pistoni in acciaio inox temperato
- Valvola di sicurezza automatica con azzeramento della pressione nella testa pompa
- Motore elettrico monofase a induzione con protezione termica
- Sistema di arresto totale dell'idropulitrice a distanza
- Pompa con testa in alluminio per mod. 2591, pompa con testa in ottone per mod. 3590

- 3 Axial stainless steel pistons wobble-plate pump with brass head
- Tempered stainless steel pistons
- Automatic by-pass valve with pump head pressure discharge
- Single-phase induction motor with thermal protector
- Remote control for total shut-down of high pressure washer
- Aluminium pump head for model 2591. Brass pump head for model 3590



HPV-O

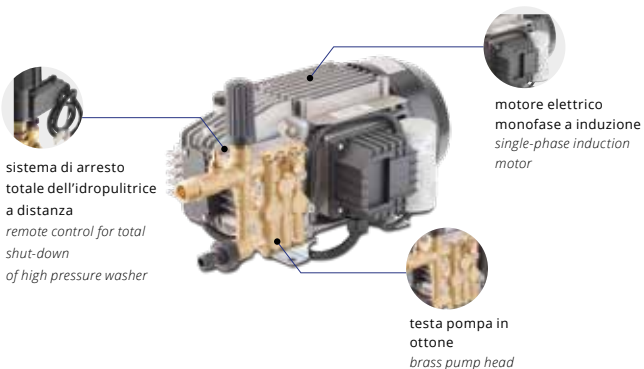

- Pompa a 3 pistoni in acciaio inox temperato con riporto ceramico con sistema biella-manovella, testa pompa in alluminio
- Valvola di sicurezza automatica con azzeramento della pressione nella testa pompa
- Motore elettrico monofase a induzione con protezione termica
- Sistema di arresto totale dell'idropultrice a distanza (mod. 4590)
- Sistema Total Stop temporizzato (mod. 5670)

- Triplex pump with tempered stainless steel ceramic coated pistons and connecting rod system with aluminum pump head
- Automatic by-pass valve with pump head pressure discharge
- Single-phase induction motor with thermal protection
- Remote control for total shut-down of high pressure washer (mod. 4590)
- Timed Total Stop system (mod. 5670)



HRC



- Pompa a 3 pistoni in ceramica con sistema biella-manovella, testa pompa in ottone
- Valvola di bypass automatica con azzeramento della pressione nella testa pompa
- Motore elettrico monofase a induzione con protezione termica (3kW)
- Motore elettrico trifase a induzione con protezione termica (5kW)
- Sistema di arresto totale dell'idropultrice a distanza
- Sistema Total Stop temporizzato

- Triplex pump with ceramic pistons and connecting rod system with brass pump head
- Automatic by-pass valve with pump head pressure discharge
- Single-phase induction motor with thermal protection (3kW)
- Three-phase induction motor with thermal protection (5kW)
- Remote control for total shut-down of high pressure washer
- Timed Total Stop system



HRCS

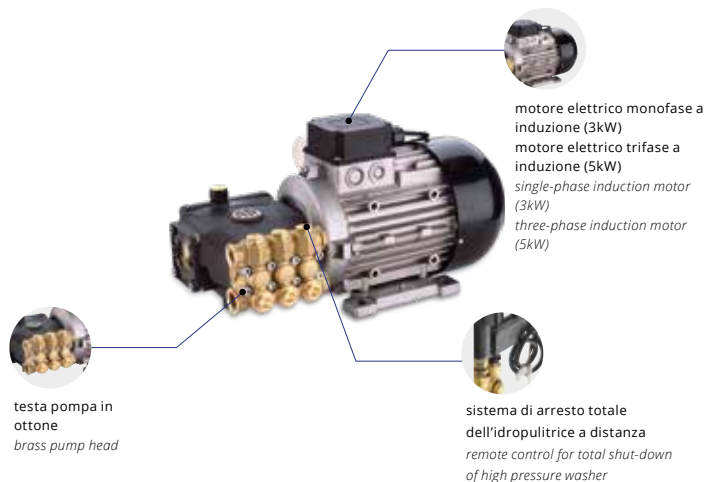

- Pompa a 3 pistoni in ceramica con sistema biella-manovella, testa pompa in ottone
- Valvola di bypass automatica con azzeramento della pressione nella testa pompa
- Motore elettrico monofase a induzione con protezione termica (3kW)
- Motore elettrico trifase a induzione con protezione termica (5kW)
- Sistema Total Stop temporizzato

- Triplex pump with ceramic pistons and connecting rod system with brass pump head
- Automatic by-pass valve with pump head pressure discharge
- Single-phase induction motor with thermal protection (3kW)
- Three-phase induction motor with thermal protection (5kW)
- Remote control for total shut-down of high pressure washer
- Inlet water suction from tank by self priming function



HRR

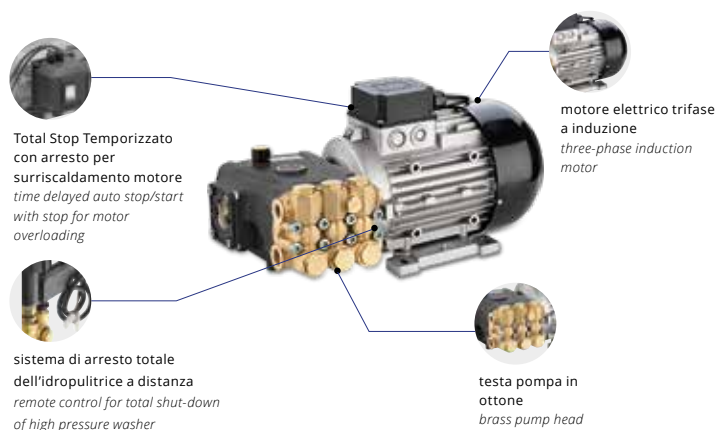

- Pompa a 3 pistoni in ceramica con sistema biella-manovella, testa pompa in ottone
- Valvola di bypass automatica con azzeramento della pressione nella testa pompa
- Motore elettrico trifase a induzione con protezione termica
- Sistema Total Stop temporizzato

- Triplex pump with ceramic pistons and connecting rod system with brass pump head
- Automatic by-pass valve with pump head pressure discharge
- Three-phase induction motor with thermal protection
- Remote control for total shut-down of high pressure washer
- Timed Total Stop system



HXW

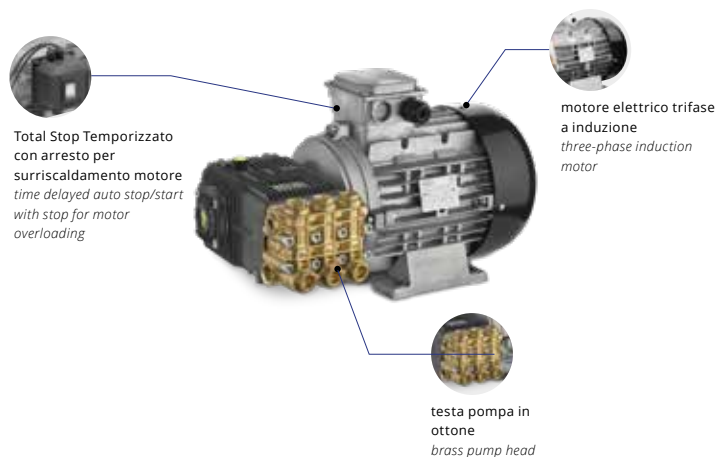

- Pompa a 3 pistoni in ceramica con sistema biella-manovella, testa pompa in ottone
- Valvola di sicurezza automatica con azzeramento della pressione nella testa pompa
- Motore elettrico trifase a induzione con protezione termica
- Sistema Total Stop temporizzato

- Triplex pump with ceramic pistons and connecting rod system with brass pump head
- Automatic by-pass valve with pump head pressure discharge
- Three-phase induction motor with thermal protection
- Time delayed auto stop/start with stop for motor overloading
- Timed Total Stop system





	HRM-A	HRM-O	HPV-O	HRC	HRCS	HRR	HXW
2591	●						
3590		●					
4590			●				
5670			●				
5850				●			
5870					●		
6640				●			
6670				●			
6950				●			
6970						●	
7850				●			
7870						●	
8840							●
8860							●
8880							●
1310			●				
1320				●			
1325				●			
1380						●	

SERIE - SERIES



SERIE 25	P 142
SERIE 35	P 142
SERIE 45	P 142
SERIE 56	P 144
SERIE 58	P 145
SERIE 66	P 146
SERIE 69	P 147
SERIE 78	P 148
SERIE 88	P 149
SERIE 13	P 150



25·35·45 Series

IDROPULTRICI ALTA PRESSIONE
high pressure washers

OLIGHTPRO

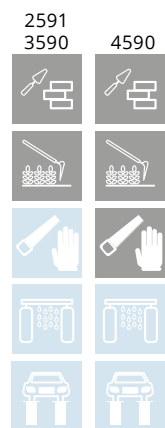

Caratteristiche Generali

- Pompa a 3 pistoni assiali comandati da piattello oscillante (2591, 3590) o con sistema biella-manovella (4590)
- Pistoni in acciaio inox temprato
- Valvola di by-pass automatica con azzeramento della pressione nella testa della pompa
- Motore elettrico a induzione con protezione termica
- Pressostato di sicurezza per spegnimento della caldaia in caso di mancanza acqua
- Caldaia verticale, doppia serpentina e fondo in materiale refrattario
- Serbatoio gasolio 4 l
- Filtro acqua e filtro aspirazione gasolio

General Features

- 3 Axial stainless steel pistons wobble-plate pump (2591, 3590) or with connecting rod system (4590)
- Tempered stainless steel pistons
- Automatic by-pass valve with pump head pressure discharge
- Single-phase induction electric motor with thermal protector
- With safety pressure switch to shut down the boiler in case of lack of water
- Vertical boiler with double heating coil and refractory compound base
- Fuel tank capacity 4 l
- Water filter and fuel inlet filter

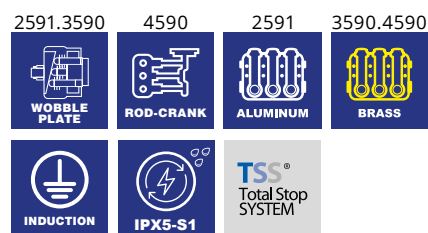
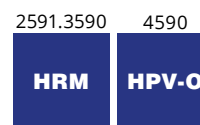

MOD	COD	MAX		MAX		kW	rpm	Hz	V	kg
		bar	psi	l/h	gph					
2591	15376	130	1900	420	111	2,2	2800	50	230~	48
3590	24425	140	2050	480	127	2,4	2800	50	230~	52
4590	24426	150	2200	500	132	2,5	2800	50	230~	52,8



°C Max	Δ°t
90	55
90	55
90	45

Accessori standard Standard accessories





OLIGHTPRO



Caratteristiche Generali

- Pompa a 3 pistoni assiali comandati dal piattello oscillante (5640) o con sistema biella-manovella (5670)
- Valvola di by-pass automatica con azzeramento della pressione nella testa della pompa
- Motore elettrico monofase con protezione termica
- Pressostato di sicurezza per spegnimento della caldaia in caso di mancanza acqua
- Caldaia verticale in acciaio inox, con sistema di raffreddamento bruciatore a chiocciola azionata da motore elettrico indipendente, doppia serpentina e fondo in cemento refrattario
- Scheda di ritardo per spegnimento caldaia
- Regolazione pressione
- Serbatoio gasolio 8 l, con tappo di scarico
- Termostato
- Aspirazione detergente incorporata
- Filtro acqua e filtro aspirazione gasolio

General Features

- 3 Axial stainless steel pistons wobble-plate pump (5640) or with connecting rod system (5670)
- Automatic by-pass valve with pump head pressure discharge
- Heavy-duty mono-phase motor with thermal protector
- With safety pressure switch to shut down the boiler in case of lack of water
- Stainless steel vertical boiler with coil burner cooling function driven by independent motor, double coil and refractory cement bottom
- Heating boiler shut-down delay circuit
- Pressure adjustment built-in
- Fuel tank with drain plug (8 l)
- Thermostat
- Built-in detergent suction
- Water filter and fuel inlet filter

HPV-O



MOD	COD	MAX	MAX		NET					
		bar	psi	l/h	gph	kW	rpm	Hz	V	kg
5670	25671	150	2200	500	132	2,5	2800	50	230~	80

Accessori standard Standard accessories



°C Max Δ°t
90 45



HEAVYPRO



Spie: tensione, gasolio, fiamma.
Termostato per regolazione temperatura acqua
Warning lights: power on, fuel, flame. Water temperature control thermostat



manico ergonomico
ergonomic handle



caldaia in acciaio
Stainless steel boiler



battistrada in gomma
rubber wheels



filtro ingresso acqua ispezionabile
inspectable water intake filter



Caratteristiche Generali

- Pompa a pistoni con sistema biella-manovella ad elevate prestazioni
- Valvola di by-pass automatica con azzeramento della pressione nella testa della pompa
- Pressostato di sicurezza per spegnimento della caldaia in caso di mancanza acqua
- Caldaia verticale in acciaio inox, con sistema di raffreddamento bruciatore a chiocciola azionata da motore elettrico indipendente, doppia serpentina e fondo in cemento refrattario
- Scheda di ritardo per spegnimento caldaia
- Regolazione pressione
- Serbatoio gasolio 8 l, con tappo di scarico
- Termostato
- Aspirazione detergente incorporata
- Filtro acqua e filtro aspirazione gasolio

General Features

- High performance piston pump with connecting rod system
- Automatic by-pass valve with pump head pressure discharge
- With safety pressure switch to shut down the boiler in case of lack of water
- Stainless steel vertical boiler with coil burner cooling function driven by independent motor, double coil and refractory cement bottom
- Heating boiler shut-down delay circuit
- Pressure adjustment built-in
- Fuel tank with drain plug (8 l)
- Thermostat
- Built-in detergent suction
- Water filter and fuel inlet filter

5850

5870

HRC

HRCS



INDUCTION



ROD-CRANK



BRASS



IPX5-S1



TST®
Total Stop System
TIMED

MOD	COD	MAX		MAX						KG NET
		bar	psi	l/h	gph	kW	rpm	Hz	V	kg
5850	25672	130	1900	600	159	3	1450	50	230~	83
5870	25673	150	2200	900	238	5	2800	50	400 3~	84

Accessori standard Standard accessories



41047 (5850)

46221

3082 (5850/1504)
3095 (5870/15055)

41847 (5870)

3164470 (5850/8 m)
3160160 (5870/10 m)



°C Max	Δt
90	55
90	70



66 Series 6640.6670

IDROPULTRICI ALTA PRESSIONE
high pressure washers

HEAVYPRO



caldaia in acciaio
Stainless steel boiler



filtro ingresso acqua
ispezionabile
inspectable water
intake filter



battistrada in gomma
rubber wheels

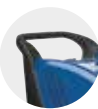

manico ergonomico
ergonomic handle



Termostato (di serie)
Thermostat (equipped
with)



ruota anteriore
pivottante
front castor wheel

Caratteristiche Generali

- Pompa a 3 pistoni in ceramica con sistema biella-manovella
- Valvola di by-pass automatica con azzeramento della pressione nella testa della pompa
- Motore elettrico con protezione termica
- Pressostato di sicurezza per spegnimento della caldaia in caso di mancanza acqua
- Caldaia verticale in acciaio verniciato, con sistema di raffreddamento bruciatore a chiocciola azionata da motore elettrico indipendente, doppia serpentina e fondo in cemento refrattario
- Scheda di ritardo per spegnimento caldaia
- Regolazione pressione
- Serbatoio gasolio 22 l, con tappo di scarico
- Termostato
- Aspirazione detergente incorporata
- Serbatoio detergente 3,5/4 l incorporato
- Filtro acqua e filtro aspirazione gasolio

General Features

- Triplex pump with ceramic pistons and connecting rod system
- Automatic by-pass valve with pump head pressure discharge
- Heavy-duty motor with thermal protector
- With safety pressure switch to shut down the boiler in case of lack of water
- Coated steel vertical boiler with coil burner cooling function driven by independent electric motor, double coil and refractory cement bottom
- Heating boiler shut-down delay circuit
- Pressure adjustment built-in
- Fuel tank with drain plug (22 l)
- Thermostat
- Built-in detergent suction
- Built-in detergent tank capacity 3.5/4 l
- Water filter and fuel inlet filter

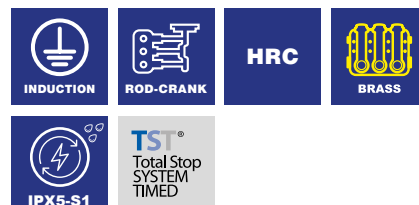

MOD	COD	MAX		MAX					KG NET	
		bar	psi	l/h	gph	kW	rpm	Hz	V	kg
6640	25275	130	1900	600	159	3	1450	50	230~	82
6670	25288	170	2500	780	206	5	1450	50	400 3~	85



°C Max	Δt
90	55
90	45

Accessori standard Standard accessories

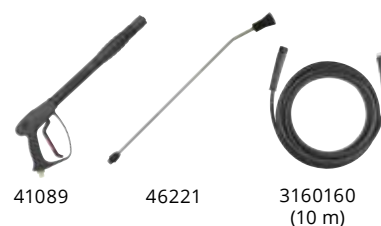

3082 (6640/1504)
3086 (6670/15045)



HEAVYPRO



manico ergonomico
ergonomic handle



battistrada in gomma
rubber wheels



spie: tensione, gasolio, fiamma
termostato per regolazione temperatura acqua
warning lights: power on, fuel, flame
water temperature control thermostat

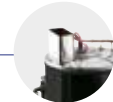

caldaia in acciaio
Stainless steel boiler



filtro ingresso acqua
ispezionabile
inspectable water intake filter

Caratteristiche Generali

- Pompa a 3 pistoni in ceramica con sistema biella-manovella
- Valvola di by-pass automatica con azzeramento della pressione nella testa della pompa
- Motore elettrico trifase con protezione termica
- Sistema di arresto totale dell'idropulitrice a distanza
- Pressostato di sicurezza per spegnimento della caldaia in caso di mancanza acqua
- Caldaia verticale in acciaio inox, con sistema di raffreddamento bruciatore a chiocciola azionata da motore elettrico indipendente, doppia serpentina e fondo in cemento refrattario
- Scheda di ritardo per spegnimento caldaia
- Regolazione pressione
- Serbatoio gasolio 14 l, con tappo di scarico
- Termostato
- Aspirazione detergente incorporata
- Serbatoio detergente 6 l incorporato
- Filtro acqua e filtro aspirazione gasolio
- Lunghezza cavo elettrico 5 m

General Features

- Triplex pump with ceramic pistons and connecting rod system
- Automatic by-pass valve with pump head pressure discharge
- Heavy-duty three-phase motor with thermal protector
- Remote control for total shut-down of high pressure cleaner
- With safety pressure switch to shut down the boiler in case of lack of water
- Stainless steel vertical boiler with coil burner cooling function driven by independent motor, double coil and refractory cement bottom
- Heating boiler shut-down delay circuit
- Pressure adjustment built-in
- Fuel tank with drain plug (14 l)
- Thermostat
- Built-in detergent suction
- Built-in detergent tank capacity 6 l
- Water filter and fuel inlet filter
- Electric cable length 5 m

	6950	6970
	HRC	HRR

MOD	COD	MAX	MAX		NET					
		bar	psi	l/h	gph	kW	rpm	Hz	V	kg
6950	24103	150	2200	900	238	5	1450	50	400 3~	94
6970	25276	200	2900	900	238	7,4	1450	50	400 3~	98



°C Max	Δ°t
90	70
90	60

Accessori standard Standard accessories





78 Series 7850.7870

IDROPULTRICI ALTA PRESSIONE
high pressure washers

HEAVYPRO

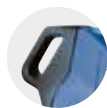

manico ergonomico
ergonomic handle

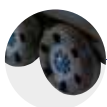

battistrada in gomma
rubber wheels



spie: tensione, gasolio, fiamma
termostato per regolazione
temperatura acqua
warning lights: power on, fuel, flame
water temperature control thermostat



caldaia in acciaio
Stainless steel boiler



filtro ingresso acqua
ispezionabile
inspectable water intake filter

Caratteristiche Generali

- Pompa a 3 pistoni in ceramica con sistema biella-manovella
- Valvola di by-pass automatica con azzeramento della pressione nella testa della pompa
- Motore elettrico trifase con protezione termica
- Sistema di arresto totale dell'idropulitrice a distanza
- Pressostato di sicurezza per spegnimento della caldaia in caso di mancanza acqua
- Caldaia verticale in acciaio inox, con sistema di raffreddamento bruciatore a chiocciola azionata da motore elettrico indipendente, doppia serpentina e fondo in cemento refrattario
- Scheda microperdite con segnalatore acustico
- Scheda di ritardo per spegnimento caldaia
- Regolazione pressione
- Serbatoio gasolio 15 l, con tappo di scarico
- Termostato
- Aspirazione detergente incorporata
- Serbatoio detergente 4/5 l incorporato
- Filtro acqua e filtro aspirazione gasolio

General Features

- Triplex pump with ceramic pistons and connecting rod system
- Automatic by-pass valve with pump head pressure discharge
- Heavy-duty three-phase motor with thermal protector
- Remote control for total shut-down of high pressure cleaner
- With safety pressure switch to shut down the boiler in case of lack of water
- Stainless steel vertical boiler with coil burner cooling function driven by independent motor, double coil and refractory cement bottom
- Minor leak detector PCB with buzzer
- Heating boiler shut-down delay circuit
- Pressure adjustment built-in
- Fuel tank with drain plug (15 l)
- Thermostat
- Built-in detergent suction
- Built-in detergent tank capacity 4/5 l
- Water filter and fuel inlet filter



INDUCTION

7850

7870



ROD-CRANK

HRC

HRR



BRASS



IPX5-S1



TST®
Total Stop
SYSTEM
TIMED

MOD	COD	MAX	MAX							KG NET
		bar	psi	l/h	gph	kW	rpm	Hz	V	kg
7850	25277	150	2200	900	238	5	1450	50	400 3~	94
7870	25278	200	2900	900	238	7,4	1450	50	400 3~	98



°C Max	Δt
90	70
90	60

Accessori standard Standard accessories

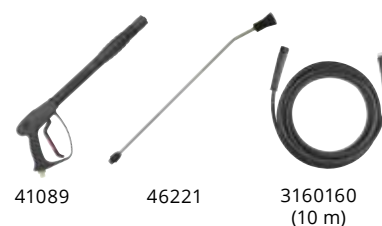

41089

46221

3160160
(10 m)

3083 (7850/1505)
3086 (7870/15045)



HEAVYPRO



Caratteristiche Generali

- Pompa a 3 pistoni in ceramica con sistema biella-manovella
- Valvola di by-pass automatica con azzeramento della pressione nella testa della pompa
- Motore elettrico trifase con protezione termica
- Sistema di arresto totale dell'idropultrice a distanza
- Pressostato di sicurezza per spegnimento della caldaia in caso di mancanza acqua
- Caldaia verticale in acciaio inox, con sistema di raffreddamento bruciatore a chiocciola azionata da motore elettrico indipendente, doppia serpentina e fondo in cemento refrattario
- Scheda microperdite con segnalatore acustico
- Scheda di ritardo per spegnimento caldaia
- Regolazione pressione
- Serbatoio gasolio 24 l, con tappo di scarico
- Termostato
- Aspirazione detergente incorporata
- Serbatoio detergente 8 l incorporato
- Filtro acqua e filtro aspirazione gasolio

General Features

- Triplex pump with ceramic pistons and connecting rod system
- Automatic by-pass valve with pump head pressure discharge
- Heavy-duty three-phase motor with thermal protector
- Remote control for total shut-down of high pressure cleaner
- With safety pressure switch to shut down the boiler in case of lack of water
- Stainless steel vertical boiler with coil burner cooling function driven by independent motor, double coil and refractory cement bottom
- Minor leak detector PCB with buzzer
- Heating boiler shut-down delay circuit
- Pressure adjustment built-in
- Fuel tank with drain plug (24 l)
- Thermostat
- Built-in detergent suction
- Built-in detergent tank capacity 8 l
- Water filter and fuel inlet filter

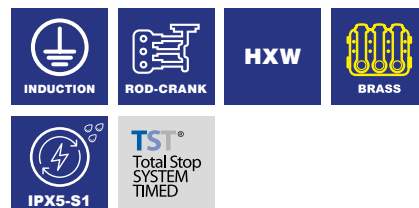

MOD	COD	MAX	MAX							KG NET
		bar	psi	l/h	gph	kW	rpm	Hz	V	kg
8840	22913	150	2200	1260	333	7,4	1450	50	400 3~	135
8860	22914	200	2900	1260	333	9,3	1450	50	400 3~	135
8880	22915	250	3600	900	238	9,3	1450	50	400 3~	135



°C Max	Δt
90	55
90	55
90	60

Accessori standard Standard accessories



- 3157 (8840/1508)
- 3084 (8860/1506)
- 3082 (8880/1504)



13 Series 1310.1320.1325

IDROPULTRICI ALTA PRESSIONE
high pressure washers

HEAVYPRO



quadro comandi
bassa tensione
low voltage
control panel



filtro ingresso acqua ispezionabile
inspectable water intake filter



caldaia in acciaio
Stainless steel boiler



porta accessori
built-in accessories
holder



battistrada in
gomma
rubber wheels

Caratteristiche Generali

- Struttura robusta con cofano in acciaio inox (AISI 430)
- Pompa a 3 pistoni in ceramica con sistema biella-manovella
- Testa pompa in ottone
- Valvola di by-pass automatica
- Motore elettrico monofase
- Protezione motore magnetotermica
- Total Stop Temporizzato
- Arresto per microperdite
- Arresto dopo 1 ora di Total Stop
- Arresto per mancanza d'acqua
- Arresto per surriscaldamento motore
- Segnalazione d'errore tramite spia intermittente
- Regolazione pressione
- Quadro comandi a bassa tensione
- Spie presenza corrente, gasolio e TST
- Quadro comandi in inox (AISI 430)
- 3 pressostati a 24 V
- Caldaia inox (AISI 430)
- Aspirazione detergente incorporata, regolabile
- Serbatoio gasolio 24 l
- Lunghezza cavo elettrico 5 m

General Features

- Heavy-duty frame with stainless steel cover (AISI 430)
- Triplex pump with ceramic pistons and connecting rod system
- Brass pump head
- Automatic by-pass valve
- Heavy-duty one-phase motor
- Magnetothermal motor overload cutout
- Time delayed auto stop/start
- Stop for leak detention
- Stop after 1 hour of total stop
- Stop for lack of water
- Stop for motor overloading
- System error warning light
- Pressure adjustment
- Low voltage control panel
- Power on, fuel level and TST lights
- Stainless steel control panel
- 3 Pressure switches at 24V
- Stainless steel boiler (AISI 430)
- Integral detergent suction with setting adjustment
- Fuel tank 24 l
- Electric cable length 5 m

1310 1320.1325

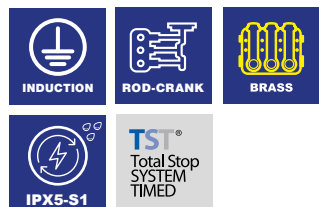

MOD	COD									
		bar	psi	l/h	gph	kW	rpm	Hz	V	kg
1310	24894	150	2200	500	133	2,5	2800	50	230~	105
1320	25273	130	1900	600	159	3	1450	50	230~	110
1325	25274	150	2200	900	238	5	2800	50	400 3~	110



versione con ruota
posteriore pivotante
rear castor wheel
version



A richiesta
on request

	°C Max	Δ°t
	90	65
	90	55
	90	60

Accessori standard Standard accessories



41047 46221 (57 cm) 3104 (1310/1503)
3082 (1320.1504)
3095 (1325.15055)



3164470 (1310/8 m)
3160160 (1320.1325/10 m)



HEAVYPRO



quadro comandi
bassa tensione
low voltage
control panel



filtro ingresso acqua ispezionabile
inspectable water intake filter



caldaia in acciaio
Stainless steel boiler



porta accessori
built-in accessories
holder



battistrada in
gomma
rubber wheels

Caratteristiche Generali

- Struttura robusta con cofano in acciaio inox (AISI 430)
- Pompa a 3 pistoni in ceramica con sistema biella-manovella
- Valvola di by-pass automatica
- Motore elettrico trifase
- Protezione motore magnetotermica
- Arresto per microperdite
- Arresto dopo 1 ora di Total Stop
- Arresto per mancanza d'acqua
- Arresto per surriscaldamento motore
- Segnalazione d'errore tramite spia intermittente
- Regolazione pressione
- Quadro comandi a bassa tensione
- Spie presenza corrente, gasolio e TST
- Quadro comandi in inox (AISI 430)
- 3 pressostati a 24 V
- Caldaia inox (AISI 430)
- Aspirazione detergente incorporata, regolabile
- Serbatoio gasolio 24 l
- Lunghezza cavo elettrico 5 m

General Features

- Heavy-duty frame with stainless steel cover (AISI 430)
- Triplex pump with ceramic pistons and connecting rod system
- Automatic by-pass valve
- Heavy-duty three-phase motor
- Magnetothermal motor overload cutout
- Time delayed auto stop/start
- Stop for leak detention
- Stop after 1 hour of total stop
- Stop for lack of water
- Stop for motor overloading
- System error warning light
- Pressure adjustment
- Low voltage control panel
- Power on, fuel level and TST lights
- Stainless steel control panel
- 3 Pressure switches at 24V
- Stainless steel boiler (AISI 430)
- Integral detergent suction with setting adjustment
- Fuel tank 24 l
- Electric cable length 5 m

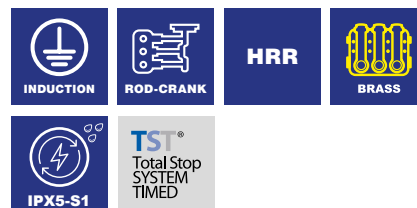

MOD	COD	MAX	MAX							KG NET
		bar	psi	l/h	gph	kW	rpm	Hz	V	kg
1380	25284	200	2900	900	238	7,4	1450	50	400 3~	150

Accessori standard Standard accessories



versione con ruota
posteriore pivotante
rear castor wheel
version



A richiesta
on request

°C Max	Δ°t
90	60









ACCESSORI

Accessories













		25 Series	35 Series	45 Series		58 Series	66 Series	69 Series	78 Series	88 Series	13 Series										
		2591	3590	4590	5670	5850	5870	6640	6670	6950	6970	7850	7870	8840	8860	8880	1310	1320	1325	1380	
Pistola Trigger gun		41047	S	S	S	S											S	S	S		
		41089						S	S	S	S	S	S	S	S	S				S	
		41847					S														
Lancia con testina fissa senza ugello Lance with fixed head w/out nozzle		50690 (56 cm)	S	S	S									S	S	S					
Lancia con testina alta/bassa press. senza ugello Lance with high/low pressure head w/out nozzle		46221 (56 cm)				S	S	S	S	S	S	S	S				S	S	S	S	
Ugelli Wash nozzles 1/4 MEG		3729 (15025)	S	S																	
		3104 (1503)			S	S												S			
		3082 (1504)					S		S								S		S		
		3086 (15045)							S		S		S								S
		3083 (1505)								S		S									
		3095 (15055)						S													S
		3084 (1506)														S					
		3157 (1508)													S						
		Lancia getto rotante PRO Rotary lance PRO		40898 (56 cm)	O	O															
41050 (56 cm)					O	O													O		
40964 (56 cm)							O		O										O	O	
40803 (56 cm)									O		O		O								O
40965 (56 cm)							O								O						O
40966 (56 cm)										O		O									
40969 (56 cm)															O						
3520550 (8 m) Reinforced				S	S	S															
Tubo AP Hose HP		3164470 (8 m) Reinforced			S	S											S				
		3160160 (10 m) Reinforced					S	S	S	S	S	S	S						S	S	S
		3160170 (10 m) Reinforced													S	S	S				
		Prolunga tubo AP Reinforced extension HP hose		40641 (15 m)	O	O	O	O	O											O	
40106 (15 m)							O	O	O	O	O	O	O	O	O	O			O	O	O
Kit schiumogeno Foam lance bottle *		40320	S	S	S																

Legenda: "S" Accessorio di serie - "O" Accessorio opzionale
"S" On board accessory - "O" Optional accessory

		25 Series	35 Series	45 Series		58 Series	66 Series	69 Series	78 Series	88 Series	13 Series										
		2591	3590	4590	5670	5850	5870	6640	6670	6950	6970	7850	7870	8840	8860	8880	1310	1320	1325	1380	
Kit schiumogeno alta pressione <i>High pressure foam lance bottle *</i> 	41552	O	O	O	O	O	O	O	O	O	O	O	O	O	O	O	O	O	O	O	
	1272520 (8 m)	O	O	O	O	O	O	O	O	O	O	O	O	O	O	O	O	O	O	O	
	Kit pulizia tubazioni <i>Pipe drain kit</i> 	1272530 (16 m)	O	O	O	O	O	O	O	O	O	O	O	O	O	O	O	O	O	O	O
		46365 (10 m) *													O						
	46367 (16 m) *													O							
Spazzola fissa <i>Fixed brush *</i> 	41577	O	O	O	O																
	Spazzola rotante <i>Rotary brush *</i> 	41578	O	O	O	O															
46370						O	O	O	O	O	O	O	O	O	O	O	O	O	O	O	
46371														O							
Lavapavimenti con serbatoio detergente <i>Patio cleaner with detergent tank d. 30 cm *</i> 	41687	O	O	O	O																
	Lavapavimenti d. 30 cm <i>Patio cleaner d. 30 cm *</i> 	46359	O	O	O	O															
Lavapavimenti PRO con regolazione <i>Patio cleaner PRO with pressure adjustment *</i> 		46368	O	O	O	O												O			
	46369					O	O		O	O	O	O	O	O	O	O	O	O	O	O	
Kit lancia sabbiante PRO <i>Sand blasting lance PRO *</i> 	41591 (50 cm)	O	O	O	O												O				
	41762 (50 cm)					O	O		O	O	O	O	O	O	O	O	O	O	O	O	
	41763 (50 cm)					O	O	O	O	O	O	O	O	O	O	O	O	O	O	O	
Sabbia calibrata e filtrata <i>Calibrated filtered sand *</i> 	3207 (5 kg)	O	O	O	O	O	O	O	O	O	O	O	O	O	O	O	O	O	O	O	
	41770 (25 kg)	O	O	O	O	O	O	O	O	O	O	O	O	O	O	O	O	O	O	O	

(* Utilizzare solo con acqua fredda
 (* Use cold water only

Legenda: "S" Accessorio di serie - "O" Accessorio opzionale
 "S" On board accessory - "O" Optional accessory

		25 Series	35 Series	45 Series		58 Series	66 Series	69 Series	78 Series	88 Series		13 Series								
		2591	3590	4590	5670	5850	5870	6640	6670	6950	6970	7850	7870	8840	8860	8880	1310	1320	1325	1380
Kit aspirazione acqua <i>Water suction kit *</i>		41592	O	O	O	O	O	O	O	O	O	O	O			O	O	O	O	O
		46374 (15025 - 75 cm)	O	O																
Kit lancia sottoscocca con ugello <i>Underbody lance with nozzle *</i>		41590 (1503 - 80 cm)		O	O												O			
		41751 (1504 - 80 cm)				O		O								O		O		
		46372 (15045 - 80 cm)							O		O		O							
		41753 (1505 - 80 cm)								O		O								
		46373 (1506 - 80 cm)						O							O					O
		41754 (1508 - 80 cm)												O						
Lancia senza ugello <i>Lance w/out nozzle</i>		40652 (90 cm)	O	O	O	O	O	O	O	O	O	O	O	O	O	O	O	O	O	O
		40653 (120 cm)	O	O	O	O	O	O	O	O	O	O	O	O	O	O	O	O	O	O
		40654 (150 cm)	O	O	O	O	O	O	O	O	O	O	O	O	O	O	O	O	O	O
		40694 (170 cm)	O	O	O	O	O	O	O	O	O	O	O	O	O	O	O	O	O	O
		40695 (200 cm)	O	O	O	O	O	O	O	O	O	O	O	O	O	O	O	O	O	O
Lancia doppia <i>Double lance</i>		3160620 (66 cm)	O	O	O	O	O	O	O	O	O	O	O	O	O	O	O	O	O	O
Ugello bassa pressione <i>Low pressure nozzle</i>		3251 (2525)	O	O	O	O	O	O	O	O	O	O	O	O	O	O	O	O	O	O
Testina doppio ugello <i>Roller nozzle</i>		3025	O	O	O	O	O	O	O	O	O	O	O	O	O	O	O	O	O	O
Ugello a vapore <i>Steam nozzle</i>		50250	O	O	O	O	O	O	O	O	O	O	O	O	O	O	O	O	O	O
Kit filtro acqua <i>Water filter kit</i>		41593	O	O	O	O	O	O	O	O	O	O	O	O	O	O	O	O	O	O
Kit attacco rapido <i>Click fast kit</i>		41580	O	O	O	O	O	O	O	O	O	O	O	O	O	O	O	O	O	O
Kit attacco rapido ottone <i>Brass click fast kit</i>		40439	O	O	O	O	O	O	O	O	O	O	O	O	O	O	O	O	O	O
Kit RLW senza tubo <i>Hose reel kit w/out hose</i>		42660	O	O	O															
		40839						O	O											
		40840								O	O	O	O	O	O	O				

Legenda: "S" Accessorio di serie - "O" Accessorio opzionale
"S" On board accessory - "O" Optional accessory



CLEANING **DIVISION**

VACUUM CLEANERS HOME

Compatti ma estremamente potenti e versatili. Studiati anche per la pulizia di piccoli spazi, gli aspiratori multiuso AR BLUE CLEAN sono la soluzione ideale per diversi tipi di sporco, sia esso solido e liquido. Rumorosità controllata e accessori pratici sono gli ingredienti perfetti per prenderti cura degli spazi a te più cari con estrema praticità.

Compact but extremely powerful and versatile. Designed for cleaning even small spaces, AR BLUE CLEAN multi-purpose vacuum cleaners are the ideal solution for different types of both solid and liquid dirt. Controlled noise levels and handy accessories are the perfect ingredients for taking care of the spaces you love with the greatest of ease.



Applicazioni ed indicatori di prestazioni Aspirapolveri Home

Vacuum Cleaners Home performance Indicators & Applications

BLUE CLEAN LEVEL

BLUE CLEAN LEVEL A
Frequenza utilizzo: occasionale
Superficie mq: piccole superfici
Intensità sporco: sporco superficiale
*Frequency of use: occasional
Surface m²: small surfaces
Dirt intensity: superficial dirt*

BLUE CLEAN LEVEL B
Frequenza utilizzo: occasionale
Superficie mq: piccole/medie superfici 20/40 m²
Intensità sporco: pulizia profonda di sporco superficiale
*Frequency of use: occasional
Surface m²: small/medium surfaces 20/40 m²
Dirt intensity: in-depth removal of superficial dirt*

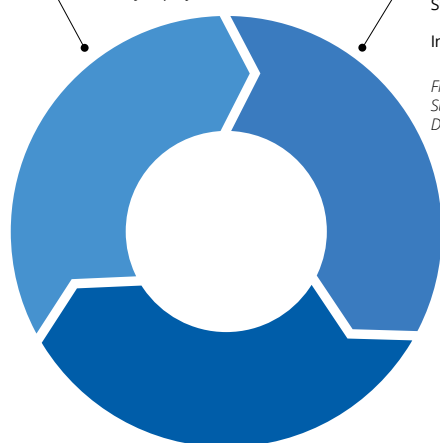

BLUE CLEAN LEVEL C
Frequenza utilizzo: quasi frequente
Superficie mq: medie superfici 40/60 m²
Intensità sporco: sporco resistente
*Frequency of use: almost frequent
Surface m²: medium surfaces 40/60 m²
Dirt intensity: stubborn dirt*

BLUE CLEAN LEVEL ti guida nella scelta del prodotto migliore, in base ad ogni esigenza di pulizia, affiancando ad ogni idropulitrice o aspiratore un'icona di livello lavaggio, insieme con le applicazioni. Ogni prodotto ha le sue caratteristiche tecniche ma anche estetiche-funzionali per soddisfare specifiche necessità del cliente, come la facilità d'uso, la compattezza, l'ergonomia, il peso, la rumorosità e la manovrabilità. Grazie al Blue Clean Level suggeriamo ad ogni cliente la combinazione migliore: è per questo che i prodotti ARBC fanno la differenza.

BLUE CLEAN LEVEL guides you in the choice of the best products for all cleaning needs, by placing a cleaning level icon next to every high pressure washer or vacuum cleaner, together with its applications. Every product has its own technical, stylistic and functional characteristics, to satisfy specific customer requirements, such as ease of use, compact size, labour-saving, weight, noise output and agility. With Blue Clean Level we direct every customer towards the ideal combination: this is why ARBC products make a real different.

BLUE CLEAN FACTOR



La combinazione ideale tra prestazioni tecniche e configurazione commerciale per poter risolvere al meglio le tue esigenze di pulizia. I prodotti che hanno il BLUE FACTOR sono i migliori, all'interno della loro categoria, per poter pulente, facilità d'utilizzo e prestazioni tecniche. Il mix perfetto per ogni tua esigenza di pulizia.

The ideal combination of technical features and commercial configuration, to deliver the best solution to your cleaning needs. Products with the BLUE FACTOR are best-in-class in cleaning power, ease of use and technical performances. The perfect mix for all your cleaning requirements.

VACUUM HOME APPLICATIONS



liquidi
fluids

grandi volumi
big volumes

interni
houses

cantine
cellars

soffitte
lofts



autorimesse
garages

balconi
balcony

cucchie
dog house,
kennels

piccoli cantieri
little
work sites

veicoli
cars



poltrone divani
armchairs
couches

spazi ristretti
limited
spaces

stufe
heaters

camini
fireplaces

griglie
grills

La gamma di aspiratori per solidi e liquidi AR BLUE CLEAN è un pratico alleato per aiutarti a mantenere la casa pulita. Dal design compatto, ma con motori potenti, sono la soluzione ideale per aspirare perfettamente qualsiasi tipo di sporco anche in piccoli spazi.

I numerosi accessori, che completano l'offerta di prodotto, permettono di pulire tutte le superfici in modo veloce, pratico e con risultati eccezionali.

The AR BLUE CLEAN range of handy solid/liquid vacuum cleaners give you practical assistance in keeping your home clean. Compact design for multi-purpose vacuum cleaners, ideal even for small spaces but with powerful motors for thorough cleaning of even the most stubborn dirt.

With the accessories that complete our product offering, you can clean all surfaces quickly, easily and with outstanding results.

31 Series 3170	●		●	●	●	●	●	●	●		●	●	●		
32 Series 3270	●		●	●	●	●	●	●	●		●	●	●		
33 Series 3370	●		●	●	●	●	●	●	●		●	●			
36 Series 3670	●		●	●	●	●	●	●	●		●	●			
37 Series 3770	●		●	●	●	●	●	●	●	●	●	●			
37 Series 3780	●	●	●	●	●	●	●	●	●	●	●	●			
Eco Series E12													●	●	●
Eco Series M20	●		●	●	●	●	●	●	●	●	●	●	●	●	●

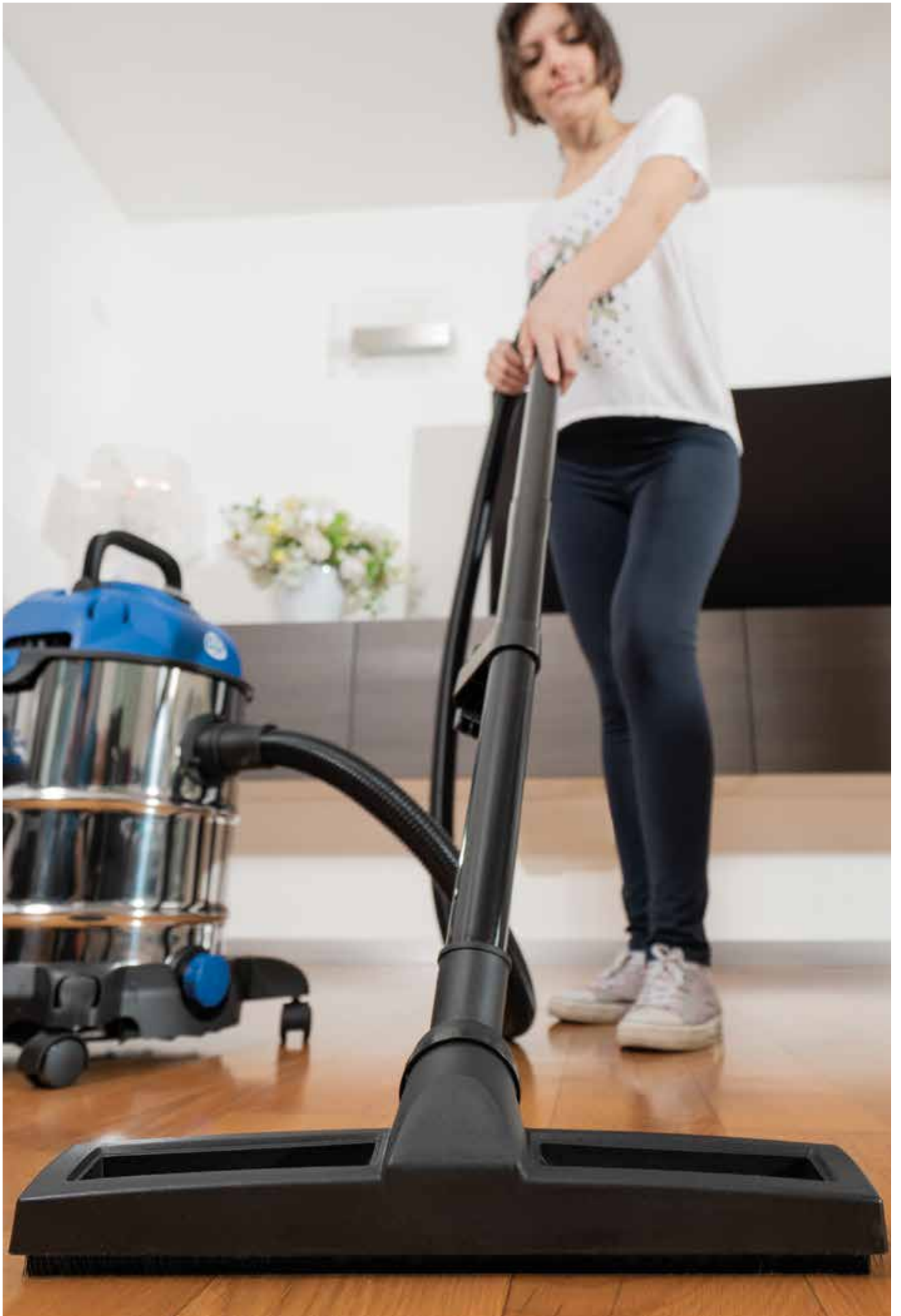

SERIE 31	P 164
SERIE 32	P 165
SERIE 33	P 166
SERIE 36	P 167
SERIE 37	P 168
E12	P 170
M20	P 171



31 Series 3170

ASPIRATORI SOLIDI LIQUIDI
wet & dry vacuum cleaners



funzione soffiante
blower function



cerniere aggancio/sgancio
rapido per pulizia filtri e fusto
quick connection/release hinges
for filter and tank cleaning

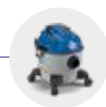

fusto raccolta in materiale plastico
plastic tank



4 ruote pivotanti e stabili
4 stable castor wheels

Caratteristiche Generali

- Aspiratore per liquidi e polveri
- Fusto raccolta in materiale plastico robusto e resistente
- Tubo d'aspirazione flessibile e resistente alla torsione
- Portaccessori integrato
- Posizione parcheggio durante le soste di lavoro
- Gancio per rimessaggio cavo d'alimentazione
- Galleggiante per interrompere l'aspirazione quando il fusto è pieno
- Cerniere aggancio-sgancio rapido per pulizia filtri e fusto
- Funzione soffiante

General Features

- Wet & Dry vacuum cleaner
- Tough, sturdy plastic tank
- Flexible, kink-resistant suction hose
- Integral accessories carrier
- Parking position for use during breaks in work
- Hook for stowing power supply cable
- Float switch to cut out suction when tank is full
- Quick connection/release hinges for filter and tank cleaning
- Blower function
- Washable high efficiency filter



MOD	COD					
		K ^{PA}	l/s	W _(MAX)	Hz	V
3170	51922-V	17	28	1200	50-60	220-240~



dB(A)

73,6



l

15



kg

5.7

Accessori standard Standard accessories



4340150

4340170

4341870
(1,5 m)



4340200



46315*



46259*
(15 l)

(* 1 pezzo in dotazione
*) 1 piece supplied

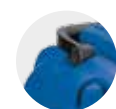

funzione soffiante
blower function



cerniere aggancio/sgancio
rapido per pulizia filtri e fusto
quick connection/release hinges
for filter and tank cleaning



fusto raccolto in materiale plastico
plastic tank



4 ruote pivotanti e stabili
4 stable castor wheels

Caratteristiche Generali

- Aspiratore per liquidi e polveri
- Fusto raccolto in materiale plastico robusto e resistente
- Tubo d'aspirazione flessibile e resistente alla torsione
- Portaccessori integrato
- Posizione parcheggio durante le soste di lavoro
- Gancio per rimessaggio cavo d'alimentazione
- Galleggiante per interrompere l'aspirazione quando il fusto è pieno
- Cerniere aggancio-sgancio rapido per pulizia filtri e fusto
- Funzione soffiante

General Features

- Wet & Dry vacuum cleaner
- Tough, sturdy plastic tank
- Flexible, kink-resistant suction hose
- Integral accessories carrier
- Parking position for use during breaks in work
- Hook for stowing power supply cable
- Float switch to cut out suction when tank is full
- Quick connection/release hinges for filter and tank cleaning
- Blower function
- Washable high efficiency filter



MOD	COD					
		K ^{PA}	l/s	W _(MAX)	Hz	V
3270	51923-V	17	28	1200	50-60	220-240~



dB(A)
73,6



l
20



kg
6.1

Accessori standard Standard accessories



4340150

4340170

4341870
(1,5 m)



4340200



46262*



46260*
(20 l)

(* 1 pezzo in dotazione
(* 1 piece supplied)



33 Series 3370

ASPIRATORI SOLIDI LIQUIDI
wet & dry vacuum cleaners



funzione soffiante
blower function



cerniere aggancio/sgancio
rapido per pulizia filtri e fusto
quick connection/release hinges for
filter and tank cleaning



fusto raccolta in acciaio inox
stainless steel tank



4 ruote pivotanti e stabili
4 stable castor wheels

Caratteristiche Generali

- Aspiratore per liquidi e polveri
- Fusto raccolta in acciaio inossidabile
- Tubo d'aspirazione flessibile e resistente alla torsione
- Portaccessori integrato
- Posizione parcheggio durante le soste di lavoro
- Gancio per rimessaggio cavo d'alimentazione
- Galleggiante per interrompere l'aspirazione quando il fusto è pieno
- Cerniere aggancio-sgancio rapido per pulizia filtri e fusto
- Funzione soffiante
- Filtro alta efficienza lavabile

General Features

- Wet & Dry vacuum cleaner
- Stainless steel tank
- Flexible, kink-resistant suction hose
- Integral accessories carrier
- Parking position for use during breaks in work
- Hook for stowing power supply cable
- Float switch to cut out suction when tank is full
- Quick connection/release hinges for filter and tank cleaning
- Blower function
- Washable high efficiency filter



MOD	COD			
		K ^{PA}	l/s	W _(MAX) Hz V
3370	51924-V	18	33	1400 50-60 220-240~



dB(A)

73,6



l

20



kg

6.3

Accessori standard Standard accessories



4340150

4340170

4341310
(2 m)



4340200



46263



46257*
(20 l)

(*) 1 pezzo in dotazione
(*) 1 piece supplied



funzione soffiante
blower function

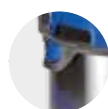

cerniere aggancio/sgancio
rapido per pulizia filtri e fusto
*quick connection/release hinges
for filter and tank cleaning*



fusto raccolta in acciaio inox
stainless steel tank

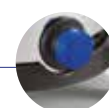

tappo di scarico
plug for draining



4 ruote pivotanti e stabili
4 stable castor wheels

Caratteristiche Generali

- Aspiratore per liquidi e polveri
- Fusto raccolta in acciaio inossidabile
- Tubo d'aspirazione flessibile e resistente alla torsione
- Portaccessori integrato
- Posizione parcheggio durante le soste di lavoro
- Gancio per rimessaggio cavo d'alimentazione
- Galleggiante per interrompere l'aspirazione quando il fusto è pieno
- Cerniere aggancio-sgancio rapido per pulizia filtri e fusto
- Funzione soffiante
- Tappo di scarico liquidi per svuotamento fusto
- Filtro alta efficienza lavabile

General Features

- Wet & Dry vacuum cleaner
- Stainless steel tank
- Flexible, kink-resistant suction hose
- Integral accessories carrier
- Parking position for use during breaks in work
- Hook for stowing power supply cable
- Float switch to cut out suction when tank is full
- Quick connection/release hinges for filter and tank cleaning
- Blower function
- Plug for draining liquids from tank
- Washable high efficiency filter



MOD	COD					
3670	51927-V	19	37	1600	50-60	220-240~

Accessori standard Standard accessories



73,6	30	6.5

(* 1 pezzo in dotazione
(* 1 piece supplied)



37 Series 3770

ASPIRATORI SOLIDI LIQUIDI
wet & dry vacuum cleaners

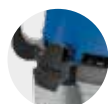

cerniere aggancio/
sgancio rapido per
pulizia filtri e fusto
*quick connection/release
hinges for filter and tank
cleaning*



4 ruote pivotanti e stabili
4 stable castor wheels



presa elettroutensile con avvio
automatico START/STOP
power tool socket with automatic START/STOP



fusto raccolta in materiale plastico
plastic tank

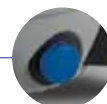

tappo per scarico liquidi
cap for drain service

Caratteristiche Generali

- Tipologia filtro: filtro alta efficienza + 1 sacchetto filtro carta
- N.4 ruote pivotanti
- Galleggiante per interrompere l'aspirazione quando il fusto è pieno
- Cerniere aggancio/sgancio rapido per pulizia filtri e fusto
- Posizione parcheggio durante le soste di lavoro
- Gancio per rimessaggio cavo d'alimentazione
- Funzione soffiante
- Funzione drenante
- Porta accessori integrato
- Resistente fusto di raccolta in plastica
- Tubo d'aspirazione resistente alla torsione

General Features

- Main filter type: High efficiency cartridge filter + 1 paper bag
- N.4 castor wheels
- Float switch to cut out suction when tank is full
- Quick connection/release hinges for filter and tank cleaning
- Parking position for use during breaks in work
- Power supply cable storage hook
- Blower function
- Drain system
- Built-in accessory holder
- Sturdy plastic tank
- Kink-resistant suction hose



MOD	COD					
		K ^{PA}	l/s	W(MAX)	Hz	V
3770	51928-V	19	39	1600	50-60	220-240~

°Potenza massima utensile 1600 W
Tool max power 1,600 W

dB(A)	l	kg NET
73,6	35	10.3

Accessori standard Standard accessories



(*) 1 pezzo in dotazione
() 1 piece supplied*



cerniere aggancio/
sgancio rapido per
pulizia filtri e fusto
*quick connection/release
hinges for filter and tank
cleaning*



2 ruote posteriori
ø18cm per
una maggiore stabilità
*2 rear wheels ø18cm for
greater stability*



tappo per scarico liquidi
cap for drain service

4 in 1



maniglia in metallo per agevolare
i movimenti
easy-to-use metal handle



presa elettroutensile con
avvio automatico START/STOP
*power tool socket with
automatic START/STOP*



fusto raccolta in acciaio inox
stainless steel tank



Caratteristiche Generali

- Tipologia filtro: filtro alta efficienza + 1 sacchetto filtro carta
- N.2 ruote anteriori pivotanti
- Galleggiante per interrompere l'aspirazione quando il fusto è pieno
- Cerniere aggancio/sgancio rapido per pulizia filtri e fusto
- Posizione parcheggio durante le soste di lavoro
- Gancio per rimessaggio cavo d'alimentazione
- Funzione soffiante
- Funzione drenante
- Porta accessori integrato
- Resistente fusto di raccolta in acciaio inox
- Tubo d'aspirazione resistente alla torsione

General Features

- Main filter type: High efficiency cartridge filter + 1 paper bag
- N.2 front castor wheels
- Float switch to cut out suction when tank is full
- Quick connection/release hinges for filter and tank cleaning
- Parking position for use during breaks in work
- Power supply cable storage hook
- Blower function
- Drain system
- Built-in accessory holder
- Stainless steel tank
- Kink-resistant suction hose



MOD	COD					
		K ^{PA}	l/s	W(MAX)	Hz	V
3780	51929-V	19	41	1600	50-60	220-240~

◊ Potenza massima utensile 1600 W
Tool max power 1,600 W

dB(A)	l	kg
73,6	50	12.7

Accessori standard Standard accessories



(* 1 pezzo in dotazione)
(1 piece supplied)*

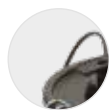

cerniere aggancio/sgancio rapido in metallo per pulizia fusto
quick connection/release metal hinges for filter and tank cleaning

2 in 1



fusto raccolta in metallo
metal tank

Caratteristiche Generali

- Aspiratore per le ceneri fredde di camini, stufe e barbecue
- Cerniere aggancio/sgancio rapido in metallo per pulizia filtro e fusto
- Fusto in acciaio
- Filtro ad alta efficienza plissettato e lavabile con protezione metallica
- Maniglia integrata
- Lunghezza cavo elettrico 1,2 m

General Features

- Fireplace, stove and barbecue cold ash vacuum cleaner
- Quick connection/release metal hinges for filter and tank cleaning
- Steel plate tank
- High-efficiency pleated and washable filter with metal guard
- Built-in handle
- Power cord length 1,2 m



MOD	COD							
		K ^{PA}	l/s	W(MAx)	Hz	V	I	kg
E12	52445	11	21	600	50	230~	12	2,5



Accessori standard Standard accessories



5060120

5060130
(1 m)

5060070



funzione soffiante
blower function



fusto raccolta in
acciaio inox
stainless steel tank



cerniere aggancio/sgancio
rapido per pulizia filtri e fusto
quick connection/release hinges
for filter and tank cleaning



4 ruote pivotanti e stabili
4 stable castor wheels



Caratteristiche Generali

- Aspiratore per ceneri, liquidi e polveri
- Fusto raccolta in acciaio inossidabile
- Tubo d'aspirazione flessibile e resistente alla torsione
- Tubo aspirazione flessibile in metallo rivestito per ceneri
- Portaccessori integrato
- Posizione parcheggio durante le soste di lavoro
- Gancio per rimessaggio cavo d'alimentazione
- Galleggiante per interrompere l'aspirazione quando il fusto è pieno
- Cerniere aggancio-sgancio rapido per pulizia filtri e fusto
- Funzione soffiante
- Filtro alta efficienza lavabile
- Cavo elettrico di 5 metri

General Features

- Ash, Wet & Dry vacuum cleaner
- Stainless steel tank
- Flexible, kink-resistant suction hose and Metal coated flexible suction hose for ash
- Integral accessories carrier
- Parking position for use during breaks in work
- Hook for stowing power supply cable
- Float switch to cut out suction when tank is full
- Quick connection/release hinges for filter and tank cleaning
- Blower function
- Washable high efficiency filter
- 5 m power cord



MOD	COD					
		K ^p A	l/s	W _(MAX)	Hz	V
M20	52013	17	28	1200	50-60	220-240~

dB(A)	l	kg
73,6	20	7,2

Accessori standard Standard accessories



(*) 1 pezzo in dotazione
(* 1 piece supplied)

CLEANING **DIVISION**

VACUUM CLEANERS PRO

Gamma tecnicamente progettata per l'aspirazione di liquidi e solidi, utilizzata quotidianamente dai migliori professionisti ed artigiani. Silenziosi e pratici raccolgono con estrema facilità lo sporco, lasciando le superfici di lavoro pulite e l'ambiente circostante sano.

Range engineered for the vacuum cleaning of liquids and solids, used everyday by top professionals and craftsmen. Quiet and convenient, they pick up dirt effortlessly, leaving work surfaces clean and the surrounding environment healthy.



Applicazioni ed indicatori di prestazioni PRO

PRO performance Indicators & Applications

BLUE CLEAN PRO LEVEL

○ LIGHTPRO

Fascia di aspiratori progettati per utilizzatori esperti che hanno necessità di eseguire lavori di pulizia che richiedono una buona capacità aspirante.

Vacuum cleaner category designed for skilled users tackling cleaning jobs operations which need plenty of good suction capacity.

● HEAVYPRO

Fascia di aspiratori progettati per professionisti che hanno necessità di eseguire lavori di pulizia che richiedono massime prestazioni.

Vacuum cleaner category designed for professionals, dealing with cleaning jobs that need the very highest-performing appliances.

BLUE CLEAN FACTOR



La combinazione ideale tra prestazioni tecniche e configurazione commerciale per poter risolvere al meglio le tue esigenze di pulizia. I prodotti che hanno il BLUE FACTOR sono i migliori, all'interno della loro categoria, per poter pulente, facilità d'utilizzo e prestazioni tecniche. Il mix perfetto per ogni tua esigenza di pulizia.

The ideal combination of technical features and commercial configuration, to deliver the best solution to your cleaning needs. Products with the BLUE FACTOR are best-in-class in cleaning power, ease of use and technical performances. The perfect mix for all your cleaning requirements.

PROFESSIONAL APPLICATIONS



artigianato
crafts



car wash



automotive

Aspiratori per solidi e liquidi con fusto in acciaio inox oppure in robusto polipropilene ideali per la pulizia dello sporco più intenso e per cui è richiesta una maggiore capacità di raccolta. Estremamente manovrabili e di facile utilizzo, garantiscono prestazioni calibrate su misura alle esigenze dei diversi clienti professionisti.

Ottimi per il lavoro quotidiano delle imprese di pulizia e di piccole imprese di artigiani, gli aspiratori della gamma ARBC PRO sono stati progettati per aspirare grosse quantità di sporco grossolano e liquido. I numerosi accessori professionali di cui sono dotati ne migliorano le prestazioni e ne rendono ancora più agevole l'utilizzo.

Vacuum cleaners with stainless steel or rugged polypropylene tank, ideal for tackling the dirtiest locations and when greater collection capacity is required. Very agile and easy to use, the ARBC PRO range of vacuum cleaners guarantees performances tailored to the needs of the various kinds of professional customers.

The solid-liquid vacuum cleaners in this range are designed to collect large quantities of coarse dirt and liquids. Excellent for everyday use by cleaning contractors and small craft workshops.

All products in this range come complete with professional accessories included in the pack, to improve their performance and make them even easier and more convenient to use.



41 Series				
4100		●		
42 Series				
4200		●		
4200P		●		
43.44 Series				
4300MP		●	●	●
4400MP		●	●	●
4300P		●	●	●
4400P		●	●	●
4300		●	●	●
4400		●	●	●
47 Series				
4700S		●		
48 Series				
4800		●		
42L Series				
4200L		●	●	●
43L Series				
4300L		●	●	●
49 Series				
4900		●		



SERIE 41	P 178
SERIE 42	P 179
SERIE 43.44	P 181
SERIE 47	P 185
SERIE 48	P 186
SERIE 42L	P 187
SERIE 43L	P 188
SERIE 49	P 189



41 Series 4100

ASPIRATORI SOLIDI LIQUIDI
wet & dry vacuum cleaners

OLIGHTPRO



Caratteristiche Generali

- Modello professionale compatto dedicato all'aspirazione di polveri e liquidi
- Fusto in acciaio inox
- Motore bi-stadio
- Ideale per la pulizia in spazi ridotti
- Galleggiante per interrompere l'aspirazione quando il fusto è pieno
- Cerniere aggancio/sgancio rapido per pulizia filtri e fusto
- Tubo d'aspirazione resistente alla torsione
- Ruote pivotanti
- Porta accessori integrato

General Features

- Professional dust and liquid vacuum cleaner
- Stainless steel body
- Two-stage motor
- Ideal for cleaning in tight spaces
- Float switch to cut out suction when tank is full
- Quick connection/release hinges for filter and tank cleaning
- Kink-resistant suction hose
- Pivoting wheels
- Built-in accessory holder



MOD	COD							
		K ^P A	l/s	STADI STAGES	W(Max)	W	Hz	V
4100	50180	22,1	47,2	2	1250	1100	50	230~

dB(A)	l	kg NET
60	20	11

Accessori standard Standard accessories



OLIGHTPRO



Caratteristiche Generali

- Modello professionale compatto dedicato all'aspirazione di polveri e liquidi
- Fusto in acciaio inox
- Motore bi-stadio
- Ideale per la pulizia in spazi ridotti
- Galleggiante per interrompere l'aspirazione quando il fusto è pieno
- Cerniere aggancio/sgancio rapido per pulizia filtri e fusto
- Tubo d'aspirazione resistente alla torsione
- Ruote pivotanti
- Porta accessori integrato

General Features

- Professional dust and liquid vacuum cleaner
- Stainless steel body
- Two-stage motor
- Ideal for cleaning in tight spaces
- Float switch to cut out suction when tank is full
- Quick connection/release hinges for filter and tank cleaning
- Kink-resistant suction hose
- Pivoting wheels
- Built-in accessory holder



MOD	COD							
		K ^{PA}	l/s	STADI STAGES	W(MAX)	W	Hz	V
4200	50181	23,5	59,7	2	1400	1200	50	230~

dB(A)	l	kg
60	36	13,7

Accessori standard Standard accessories





42 Series 4200P

ASPIRATORI SOLIDI LIQUIDI
wet & dry vacuum cleaners

OLIGHTPRO



Cerniere aggancio/sgancio rapido per pulizia filtri e fusto
Quick connection/release hinges for filter and tank cleaning



Fusto raccolta in materiale plastico robusto e resistente
Tough, sturdy plastic tank

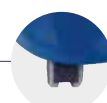

4 ruote pivotanti e stabili
4 stable castor wheels



Caratteristiche Generali

- Serie professionale compatta dedicata all'aspirazione di polveri e liquidi
- Fusto in polipropilene
- Motore bi-stadio
- Ideale per la pulizia in spazi ridotti

General Features

- Professional dust and liquid vacuum cleaner series
- Polypropylene body
- Two-stage motor
- Ideal for cleaning in tight spaces

1400 W

36 lt

Ø 40

MOD	COD							
		K ^{PA}	l/s	STADI STAGES	W(MAX)	W	Hz	V
4200P	51061	23,5	59,7	2	1400	1200	50	230~

dB(A)	l	kg
60	36	12,6

Accessori standard Standard accessories



HEAVYPRO



Caratteristiche Generali

- Modello professionale compatto dedicato all'aspirazione di polveri e liquidi
- Fusto in polipropilene
- Motore ad alta efficienza
- Galleggiante per interrompere l'aspirazione quando il fusto è pieno
- Cerniere aggancio/sgancio rapido per pulizia filtri e fusto
- Tubo d'aspirazione resistente alla torsione
- Ruote pivotanti antitraccia
- Porta accessori integrato

General Features

- Professional dust and liquid vacuum cleaner
- Polypropylene body
- High efficiency motors
- Float switch to cut out suction when tank is full
- Quick connection/release hinges for filter and tank cleaning
- Kink-resistant suction hose
- No markings pivoting wheels
- Built-in accessory holder

4300MP	4400MP
2400 W	3300 W
	77 lt
	Ø 40

MOD	COD									
		K ^{PA}	I/s	N°	STADI STAGES	W(MAX)	W	Hz	V	
4300MP	52507	20,5	94,5	2	1	2400	2050	50	230~	
4400MP	52508	20,5	141,7	3	1	3300	2900	50	230~	

Accessori standard Standard accessories



dB(A)	l	kg
67	77	22
68	77	27



43.44 Series 4300P.4400P

ASPIRATORI SOLIDI LIQUIDI
wet & dry vacuum cleaners

HEAVYPRO



Caratteristiche Generali

- Modello professionale compatto dedicato all'aspirazione di polveri e liquidi
- Fusto in polipropilene
- Motore bi-stadio
- Galleggiante per interrompere l'aspirazione quando il fusto è pieno
- Cerniere aggancio/sgancio rapido per pulizia filtri e fusto
- Tubo d'aspirazione resistente alla torsione
- Ruote pivotanti
- Porta accessori integrato

General Features

- Professional dust and liquid vacuum cleaner
- Polypropylene body
- Two-stage motor
- Float switch to cut out suction when tank is full
- Quick connection/release hinges for filter and tank cleaning
- Kink-resistant suction hose
- Pivoting wheels
- Built-in accessory holder

4300P 4400P

2400 W	3300 W
77 lt	77 lt
Ø 40	Ø 40

MOD	COD									
		K ^{PA}	l/s	N°	STADI STAGES	W(Max)	W	Hz	V	
4300P	52509	22,1	94,5	2	2	2400	2050	50	230~	
4400P	52510	22,1	141,7	3	2	3300	2900	50	230~	

Accessori standard Standard accessories



dB(A)	l	kg
67	77	22
68	77	27

HEAVYPRO



Caratteristiche Generali

- Modello professionale compatto dedicato all'aspirazione di polveri e liquidi
- Fusto in acciaio inox
- Motori bi-stadio
- Galleggiante per interrompere l'aspirazione quando il fusto è pieno
- Cerniere aggancio/sgancio rapido per pulizia filtri e fusto
- Tubo d'aspirazione resistente alla torsione
- Ruote pivotanti antitraccia
- Porta accessori integrato

General Features

- Professional dust and liquid vacuum cleaner
- Stainless steel body
- Two-stage motors
- Float switch to cut out suction when tank is full
- Quick connection/release hinges for filter and tank cleaning
- Kink-resistant suction hose
- No markings pivoting wheels
- Built-in accessory holder



MOD	COD									
		K ^{PA}	l/s	N°	STADI STAGES	W(Max)	W	Hz	V	
4300	52511	22,1	94,5	2	2	2400	2050	50	230~	



dB(A)	l	kg
67	77	24

Accessori standard Standard accessories





44 Series 4400

ASPIRATORI SOLIDI LIQUIDI
wet & dry vacuum cleaners

HEAVYPRO



fusto basculante
body which tilts for
emptying



fusto raccolta in acciaio inox
stainless steel tank



2 ruote posteriori con
battistrada in gomma
2 rubber rear wheels



2 ruote pivotanti e stabili
2 stable castor wheels



Caratteristiche Generali

- Modello professionale compatto dedicato all'aspirazione di polveri e liquidi
- Fusto in acciaio inox
- Motori bi-stadio
- Galleggiante per interrompere l'aspirazione quando il fusto è pieno
- Cerniere aggancio/sgancio rapido per pulizia filtri e fusto
- Tubo d'aspirazione resistente alla torsione
- Ruote pivotanti antitraccia
- Porta accessori integrato

General Features

- Professional dust and liquid vacuum cleaner
- Stainless steel body
- Two-stage motors
- Float switch to cut out suction when tank is full
- Quick connection/release hinges for filter and tank cleaning
- Kink-resistant suction hose
- No markings pivoting wheels
- Built-in accessory holder

3300 W

77 lt

Ø 40

MOD	COD								
		K ^{PA}	l/s	N°	STADI STAGES	W(MAX)	W	Hz	V
4400	52512	22,1	141,7	3	2	3300	2900	50	230~



dB(A)	l	kg
68	77	29

Accessori standard Standard accessories



HEAVYPRO



Caratteristiche Generali

- Modello professionale compatto dedicato all'aspirazione di polveri e liquidi
- Fusto in acciaio inox
- Motori bi-stadio
- Ideale per la pulizia in spazi ridotti
- Galleggiante per interrompere l'aspirazione quando il fusto è pieno
- Cerniere aggancio/sgancio rapido per pulizia filtri e fusto
- Tubo d'aspirazione resistente alla torsione
- Ruote pivotanti
- Porta accessori integrato
- Presa elettrica per elettroutensile

General Features

- Professional dust and liquid vacuum cleaner
- Stainless steel body
- Two-stage motors
- Ideal for cleaning in tight spaces
- Float switch to cut out suction when tank is full
- Quick connection/release hinges for filter and tank cleaning
- Kink-resistant suction hose
- Pivoting wheels
- Built-in accessory holder
- Electric socket for power tool



MOD	COD							
4700S [°]	51065	23,5	59,7	2	1400	1200	50	230~

[°] Potenza massima utensile 1400 W
Tool max power 1,400 W

60	36	14

Accessori standard

Standard accessories



HEAVYPRO



Caratteristiche Generali

- Modello professionale dedicato all'aspirazione di sole polveri
- Fusto in acciaio inox
- Motore bi-stadio
- Con presa elettrica per elettroutensile e dispositivo scuotifiltro automatico
- Filtro ad alta efficienza

General Features

- Professional vacuum cleaner for dry materials only
- Stainless steel body
- Two-stage motor
- With power tool socket and automatic filter shaker device
- High efficiency filter



MOD	COD								
		K ^{PA}	l/s	STADI STAGES	W(MAX)	W	Hz	V	
4800 [°]	51203	23,5	59,7	2	1400	1200	50	230~	

[°] Potenza massima utensile 1400 W
Tool max power 1,400 W

dB(A)	l	kg
60	37	13,9

Accessori standard Standard accessories



50212 (3,3 m)



51073 (Ø202)



Kit 51108 NOT INCLUDED

HEAVYPRO



Caratteristiche Generali

- Modello professionale dedicato alla pulizia di tappeti, poltrone e pavimenti
- Motore bi-stadio
- Serbatoio detergente incorporato (capacità 8l)
- Fusto in plastica
- L'utilizzo è sempre associato alla contemporanea erogazione ed aspirazione di detergente (acqua o miscela di acqua e detergente idoneo da effettuare prima di immettere nel serbatoio con portata di 0,8 l/min a 2 bar di pressione)

General Features

- Professional vacuum cleaner for cleaning carpets, upholstery and floors
- Two-stage motor
- Built-in detergent tank (capacity 8 l)
- Plastic body
- When in operation, it simultaneously delivers and sucks in detergent (water or a mixture of water and a suitable detergent, to be prepared before transfer to the tank) with a flow rate of 0.8 l/min at a pressure of 2 bar.



MOD	COD				
		K ^P A	l/s	STADI STAGES	W(MAx) W Hz V
4200L	51289	23,5	59,7	2	1400 1200 50 230~

l/min	bar	W	l
0,8	2	48	8

dB(A)	l	kg
60	36	14

Accessori standard Standard accessories





43L Series 4300L

ASPIRATORI SOLIDI LIQUIDI
wet & dry vacuum cleaners

HEAVYPRO



fusto basculante
body which tilts for emptying



serbatoio detergente incorporato (20l)
built-in detergent tank (20 l)



2 ruote posteriori con battistrada in gomma
2 rubber rear wheels



presa detergente
detergent socket



fusto raccolta in acciaio inox
stainless steel tank

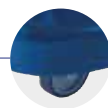

2 ruote pivotanti e stabili
2 stable castor wheels



Caratteristiche Generali

- Modello professionale dedicato alla pulizia di tappeti, poltrone e pavimenti
- Motori bi-stadio
- Serbatoio detergente incorporato (capacità 20l)
- Fusto basculante in acciaio inox
- L'utilizzo è sempre associato alla contemporanea erogazione ed aspirazione di detergente (acqua o miscela di acqua e detergente idoneo da effettuare prima di immettere nel serbatoio con portata di 0,8 l/min a 2

General Features

- Professional vacuum cleaner for cleaning carpets, upholstery and floors
- Two-stage motors
- Built-in detergent tank (capacity 20 l)
- Tilting stainless steel body
- When in operation, it simultaneously delivers and sucks in detergent (water or a mixture of water and a suitable detergent, to be prepared before transfer to the tank) with a flow rate of 0.8 l/min at a pressure of 2 bar.

2400 W

76 lt

Ø 40

MOD	COD								
		K ^P A	l/s	N°	STADI STAGES	W(MAX)	W	Hz	V
4300L	51205	23,5	94,5	2	2	2400	2300	50	230~

l/min	bar	W	l
0,8	2	48	20

dB(A)	l	kg
67	76	27,5

Accessori standard Standard accessories



51215 (2,5 m)



51216



51070



HEAVYPRO



fusto basculante
body which tilts for
emptying



fusto raccolta in acciaio inox
stainless steel tank



2 ruote posteriori con
battistrada in gomma
2 rubber rear wheels



2 ruote pivotanti e stabili
2 stable castor wheels



Caratteristiche Generali

- Modello professionale dedicato all'aspirazione di trucioli da lavorazioni metalliche industriali
- Filtro di aspirazione ad elevata superficie filtrante e protezione a barriera
- Fusto in acciaio inox
- Motori bi-stadio
- Carrello, maniglia e fusto basculante per svuotamento
- Filtro ad alta efficienza

General Features

- Model specifically designed for collection of shavings from industrial metalworking processes
- Suction filter with large filtering surface area and barrier protection
- Stainless steel body
- Two-stage motors
- Trolley, handle and tilting body for emptying
- High efficiency filter

3600 W	77 lt
Ø 50	

MOD	COD									
		K ^{PA}	l/s	N°	STADI STAGES	W(MAX)	W	Hz	V	
4900	51067	23,5	179,2	3	2	3600	3150	50	230~	



dB(A)	l	kg
68	77	29,8

Accessori standard Standard accessories



ACCESSORI

Accessories





ACCESSORI SPECIALI

SPECIAL ACCESSORIES

ACCESSORIO 3 IN 1

SIDEKICK PRO

Cod. 46267

L'accessorio 3 in 1 ARBC è un aiuto nei lavori di bricolage domestici. Ha una tripla funzione: sorregge piccole mensole o listelli; permette di regolarne l'altezza grazie al supporto rotante a 360°; raccoglie la polvere di fori da trapano su pareti e soffitti.

AR Blue Clean Sidekick Pro accessory is a helpful tool in domestic and DIY works. It has a triple function: supports small shelves or strips; allows you to adjust the height thanks to the 360° rotating support; collects dust from drill holes on walls and ceilings.





RACCOGLIPOLVERE DA FORATURA

DRILLDUST COLLECTOR

Cod. 46266

L'accessorio raccogli-polvere da foratura per aspiratori solidi e liquidi ARBC permette di raccogliere la polvere generata dall'utilizzo di trapani e avvitatori.

DrillDust Collector accessory for AR Blue Clean solid and liquid vacuum cleaners allows to collect the dust from drills and screwdrivers.

VENTOSA STURATUBI

DRAIN UNBLOCKER

Cod. 46265

L'accessorio ventosa sturatubi per aspiratori solidi e liquidi ARBC consente di liberare e ripulire gli scarichi intasati. Grazie alla potenza dell'aspirazione garantisce una pulizia profonda senza residui. L'innovativo design permette l'aderenza a tutte le tipologie di scarichi.

The Drain Unblocker accessory for AR Blue Clean solid and liquid vacuum cleaners allows you to free and clean up clogged drains. Thanks to the suction power guarantees a deep cleaning without residues. The innovative design allows adherence to all kind of drains.





















Vacuum cleaners Series

ACCESSORI
accessories

			31 Series	32 Series	33 Series	36 Series	37 Series		ASH cleaners	41 Series	42 Series	43 Series	44 Series	43 Series	44 Series	43 Series	44 Series	48 Series	42 Series	43 Series	49 Series			
			3170	3270	3370	3670	3770	3780	E12 M20	4100	4200	4200P	4300MP	4400MP	4300P	4400P	4300	4400	4700S	4800	4200L	4300L	4900	
Spazzola per pavimenti secco/umido <i>Floor wet&dry brush</i>		4340150 (ø35)	S	S	S	S	S		S															
Spazzola per pavimenti per umido <i>Brush for wet floor</i>		4341430 (ø35) 4341330 (ø40)	O	O	O	O	O	S	O															
Spazzola combinata in plastica per pavimenti <i>Combined plastic floor brush</i>		4341340 (ø35) solo secco <i>dry only</i>	O	O	O	O	O		O															
Spazzola combinata con inserto metallico per pavimenti <i>Combined metal floor brush</i>		4340750 (ø35) solo secco <i>dry only</i> 4341370 (ø40) solo secco <i>dry only</i>	O	O	O	O	O		O															
Spazzola per pavimenti combinata solo secco <i>Combined floor brush dry only</i>		46254 (ø35)	O	O	O	O	O	O	O															
Spazzola per pulizia tappeti e poltrone <i>Carpet and upholstery brush</i>		4340180 (ø35)	O	O	O	O	O		S															
Spazzola rotonda <i>Round brush</i>		46255 (ø35) 4341360 (ø40)	O	O	O	O	O		O															
Bocchetta per superfici secco/umido <i>Wet&dry nozzle</i>		4340740 (ø40)						O																
Bocchetta per fessure <i>Crevice nozzle</i>		4340170 (ø35)	S	S	S	S	O		S															
Bocchetta grande per fessure <i>Wide crevice nozzle</i>		4340730 (ø35)	O	O	O	O	S																	
Bocchetta per fessure <i>Crevice nozzle</i>		4341350 (ø40)						S																
Ventosa sturatubi <i>Suction cup drain unblocker</i>		46265	O	O	O	O	O	O	O															
Raccogli polvere da foratura <i>Drilldust collector</i>		46266	O	O	O	O	O	O	O															
Accessorio 3in1 <i>Sidekick Pro 3in1</i>		46267	O	O	O	O	O	O	O															

Legenda: "S" Accessorio di serie - "O" Accessorio opzionale
"S" On board accessory - "O" Optional accessory













		31 Series	32 Series	33 Series	36 Series	37 Series	ASH cleaners	41 Series	42 Series	43 Series	44 Series	43 Series	44 Series	43 Series	44 Series	47 Series	48 Series	42 Series	43 Series	49 Series			
		3170	3270	3370	3670	3770	3780	E12 M20	4100	4200	4200P	4300MP	4400MP	4300P	4400P	4300	4400	4700S	4800	4200L	4300L	4900	
Adattatore per elettrooutensili <i>Adapter for power tools</i>		46264				S	S																
Tubo di aspirazione con gomito <i>Suction hose with elbow</i>		4341870 (ø35/1,5 m)	S	S																			
		4341310 (ø35/2 m)	O	O	S	S	S		S														
		4341320 (ø40/2 m)						S															
		4341780 (ø35/5 m)	O	O	O	O	O																
Tubo rigido di aspirazione in plastica <i>Plastic suction tube</i>		4341800 (ø35/10 m)					O																
		4341790 (ø40/5 m)	O	O	O	O	O																
		4341810 (ø40/10 m)						O															
Tubo rigido di aspirazione in metallo <i>Metal suction tubes</i>		4340200 (ø35/3x330 mm)	S	S	S			S															
		4340210 (ø35/2x470 mm)				S	S																
		4341880 (ø40/2x480 mm)						S															
Tubi rigidi di aspirazione in metallo <i>Metal suction tubes</i>		4340230 (ø35/2x470 mm)	O	O	O	O	O		O														
		4341380 (ø40/2x480 mm) con gancio rimessaggio w/ storage hook						O															
Tubo telescopico in acciaio inossidabile <i>Stainless steel telescopic tube</i>		4340240 (ø35/480-780mm)	O	O	O	O	O		O														
Sacchetto filtro carta <i>Paper filter bag</i> 5 pcs		46256 (15 l)	O																				
		46257 (20 l)		O	S				O														
		46258 (30 l)				S																	
		46270 (35 l)					S																
		46271 (50 l)						S															
Filtro stoffa lavabile <i>Washable fabric filter bag</i> 2 pcs		46259 (15 l)	S																				
		46260 (20 l)		S	O				O														
		46261 (30 l)				O																	
		46313 (35 l)					O																
	46314 (50 l)						O																

Legenda: "S" Accessorio di serie - "O" Accessorio opzionale
"S" On board accessory - "O" Optional accessory



Vacuum cleaners Series

ACCESSORI
accessories

			31 Series	32 Series	33 Series	36 Series	37 Series	ASH cleaners	41 Series	42 Series	43 Series	44 Series	43 Series	44 Series	43 Series	44 Series	47 Series	48 Series	42 Series	43 Series	49 Series				
			3170	3270	3370	3670	3770	3780	E12 M20	4100	4200	4200P	4300MP	4400MP	4300P	4400P	4300	4400	4700S	4800	4200L	4300L	4900		
Filtro in spugna Sponge filter 5 pcs		46315	S																						
		46262		S	O	O	O	O																	
		47126								S															
Filtro cartuccia ad alta efficienza High efficiency cartridge		46269 (h= 91 mm)	O																						
		46263 (h= 115 mm)		O	S	S	S	S																	
Tubo aspirazione flessibile in metallo Flexible metal hose		5060130 (ø35 mm/1 m)							S																
		4341700 (ø40 mm/1,2 m)								S															
Tubo in alluminio Aluminum suction tube		5060070 (ø34 mm/23 cm)							S																
		4341710 (ø34 mm/23 cm)								S															
Prefiltro in tessuto ritardante Fire retardant prefilter		43575							O	O															
Filtro cartuccia Cartridge filter		47127 (h= 115 mm)							S																
Filtro alta efficienza plissettato con protezione metallica High efficiency pleated filter with metal guard		5060120 (h= 115 mm)							S																
Spazzola pavimenti combinata in acciaio Steel combined brush		50200 (ø36)							S																
Spazzola completa liquidi Floor brush (only wet)		50201 (ø36)							S																
		50208 (ø37)								S	S														
		50210 (ø37/L 400 mm)											O	O	O	O	O	O							
Spazzola pavimenti Floor brush		50207 (ø37)							S	S															
		50209 (ø37)											O	O	O	O	O	O							
Corpo spazzola Nozzle body		52517 (ø40)										S	S	S	S	S	S								
Inserto spazzola pavimenti per secco Dry floor brush insert		51090										S	S	S	S	S	S								
Inserto spazzola pavimenti per umido Wet floor brush insert		51091										S	S	S	S	S	S								

Legenda: "S" Accessorio di serie - "O" Accessorio opzionale
"S" On board accessory - "O" Optional accessory

			31 Series	32 Series	33 Series	36 Series	37 Series	3780	E12	ASH cleaners	M20	4100	4200	4200P	4300MP	4400MP	4300P	4400P	4300	4400	4700S	4800	4200L	4300L	4900	
Bocchettina <i>Small tool</i>		50195 (ø36)										S														
Spazzola rotonda <i>Round brush</i>		50199 (ø36)										S														
		50204 (ø40)											S	S	S	S	S	S	S	S						
Lancia piatta <i>Crevice nozzle</i>		50203 (ø40)											S	S	S	S	S	S	S	S						
Tubo flessibile completo <i>Complete hose</i>		50194 (ø36/2 m)										S														
		50202 (ø40/2,5 m)											S	S	S	S	S	S	S	S	S					
Tubo in metratura <i>Hose supplied by the metre</i>		51019 (ø36/30 m)										O														
		51115 (ø40/15 m)											O	O	O	O	O	O	O	O	O	O	O			
		51391 (ø40/30 m)											O	O	O	O	O	O	O	O	O	O	O			
Tubo flessibile + tubo idrolitico <i>Flexible hose + hydrolytic hose</i>		51215 (ø40/2,5 m)																					S	S		
Tubo flessibile + manicotti elettrotensile <i>Flexible hose with tool fitting collars</i>		50212 (ø28/3,3 m)																			S	S				
Tubo PU antistatico <i>Antistatic PU hose</i>		51074 (ø50 / 2,5 m)																							S	
Tronco conico antistatico <i>Tapered antistatic attachment</i>		51077 (ø50)																							S	
Ventosa ondulata antistatica <i>Corrugated antistatic sucker</i>		51076 (ø50)																							S	
Corpo spazzola polveri <i>Carpet brush body</i>		51216 (ø36)																					S	S		
Tubo prolunga plastica <i>Plastic suction tube</i>		51160 (ø36)										O	O													
		51207 (ø40)													O	O	O	O	O	O	O	O	O	O	O	O
Tubo acciaio dritto <i>Chrome straight extension</i>		50197 (ø36)										S														
		50206 (ø36)												S	S	S	S	S	S	S	S					
Tubo acciaio curvo <i>Chrome curved extension wand</i>		50205 (ø40)											S	S	S	S	S	S	S	S						

Legenda: "S" Accessorio di serie - "O" Accessorio opzionale
"S" On board accessory - "O" Optional accessory



Vacuum cleaners Series

ACCESSORI
accessories

		31 Series	32 Series	33 Series	36 Series	37 Series	ASH cleaners	41 Series	42 Series	43 Series	44 Series	43 Series	44 Series	43 Series	44 Series	47 Series	48 Series	42 Series	43 Series	49 Series					
		3170	3270	3370	3670	3770	3780	E12	M20	4100	4200	4200P	4300MP	4400MP	4300P	4400P	4300	4400	4700S	4800	4200L	4300L	4900		
Tubo acciaio curvo maschio <i>Chrome curved extension wand male</i>		51131																						O	
Lancia conica antistatica <i>Tapered antistatic lance</i>		51075 (ø50)																							S
Lancia zincata <i>Galvanised lance</i>		51078 (ø50)																							S
Kit set accessori <i>Complete accessories kit</i>		51108																		O	O				O
Manicotto zincato giunto accessori <i>Galvanised accessories fitting collar</i>		51079 (ø50)																							S
Kit terminali per tubo in metratura <i>End piece kit for hose supplied by metre</i>		51177 (ø36)								O															
		51300 (ø28)																							O
		51176 (ø40)									O	O	O	O	O	O	O	O	O	O	O				
Manicotto per prolunga tubo flessibile <i>Connector for hose supplied by meter</i>		51206 (ø36)								O															
		51319 (ø40)									O														
		51166 (ø40)																							O
Lancia lavapavimenti <i>Floor cleaning lance</i>		51217																							O
Dispositivo anti schiuma <i>Anti foam device</i>		50277									O	O	O	O	O	O	O	O	O						
Ciclone <i>Cyclon</i>		51081 (ø300)																							S
Aspiraliquidi <i>Liquid vacuum</i>		51474													O	O	O	O							O
Wet & Dry	 	(A) 51131 + (B) 51134																							O
Kit cestello separatore oli/ trucioli metallici <i>Oil/metal shaving basket filter kit</i>		51148																							O
Filtro sacchetto carta <i>Paper filter</i>		50231 (20 l) 10 pcs								O															
		51068 (36 l) 10 pcs									O	O													
		51082 (77 l) 5 pcs											O	O	O	O	O	O							

Legenda: "S" Accessorio di serie - "O" Accessorio opzionale
"S" On board accessory - "O" Optional accessory

			31 Series	32 Series	33 Series	36 Series	37 Series	ASH cleaners	41 Series	42 Series	43 Series	44 Series	43 Series	44 Series	43 Series	44 Series	47 Series	48 Series	42 Series	43 Series	49 Series			
			3170	3270	3370	3670	3770	3780	E12	M20	4100	4200	4200P	4300MP	4400MP	4300P	4400P	4300	4400	4700S	4800	4200L	4300L	4900
Filtro in poliestere <i>Polyester filter</i>		51150 (20 l) 10 pcs									O													
		51084 (36 l) 5 pcs										O	O								O			
		51071 (77 l) 5 pcs														O		O						
Filtro in nylon <i>Nylon filter</i>		50211 (ø34)									O	O	O							O				
		51072 (ø44)												O	O	O	O	O	O					
Filtro in poliestere <i>Polyester filter</i>		50413 (ø340)										S	S							S	O			
		50368 (ø440)												S	S	S	S	S	S					
		51161 (ø340)									S													
Filtro spugna per liquidi <i>Sponge filter for wet uses</i>		51083 (ø440)																						O
		51070									S	S	S	S	S	S	S	S	S	S	S	S	S	S
Filtro cartuccia conico <i>Conical cartridge filter</i>		51073 (ø202)																			S			
Filtro cartuccia <i>Cartridge filter</i>		50230 (ø175)									O	O	O								O			
		50233 (ø250)												O	O	O	O	O	O					
		51080 (ø250 polyester)																						S

Legenda: "S" Accessorio di serie - "O" Accessorio opzionale
"S" On board accessory - "O" Optional accessory

WATER PUMPS

Le pompe Annovi Reverberi sono la soluzione perfetta per liberare dall'acqua ambienti come piscine, vasche, laghetti, oppure per l'irrigazione di piante e vegetazione. Sono inoltre in grado di rimuovere l'acqua in eccesso causata da allagamenti di tipo domestico o naturale. Grazie alla funzione dell'autoclave possono integrarsi con l'approvvigionamento idrico domestico per riutilizzare l'acqua piovana o proveniente da fonti alternative per scarichi o lavatrici, evitando così l'eventuale spreco di acqua potabile.

The Annovi Reverberi pumps are the perfect solution to free water from environments such as swimming pools, ponds, or for watering plants and vegetation. They are also able to remove excess water caused by domestic or natural flooding.

Thanks to the autoclave function, they can be integrated with domestic water supply to reuse rainwater or water coming from alternative sources for drains or washing machines, thus avoiding any waste of drinking water.





ARGP 600P	P 208
ARGP 800X	P 209
ARGP 1100X	P 210
ARGP 600PB	P 214
ARGP 800XB	P 215
ARGP 1100XB	P 217
ARUP 250PC	P 220
ARUP 400PC	P 220
ARUP 750XC	P 221
ARUP 750PT	P 222
ARUP 1100XD	P 225



Applicazioni

Applications



irrigazione manuale
manual irrigation



irrigazione automatica
automatic irrigation



acque per i servizi
water supply



allagamenti domestici
house flooded



pozzetti
wells



piscine
swimming pools



cantieri
construction site



stagni/laghetti
ponds



allagamenti
floodings

Caratteristiche

Features



pressione massima
max pressure



portata massima
max flow



dimensioni di montaggio
fitting dimensions



ON/OFF automatico
automatic ON/OFF



sistema di scarico
drain system

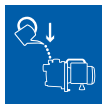

facile riempimento
easy fill



impugnatura ergonomica
handle

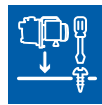

montaggio da tavolo
table mounting



serbatoio
tank



ON/OFF automatico
automatic ON/OFF

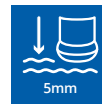

acqua residua
residual water



dimensione massima particolato
max grain size



altezza variabile
variable height



corpo in acciaio inossidabile
stainless steel body



testata pompa in acciaio inossidabile
stainless steel pump head



adatto ad acque pulite
suitable for clean water



adatto ad acque sporche
suitable for dirty water



Autoadescanti Self-priming

Model	Icon	MAX 6m 0,6bar	MAX 3100l/h	Ø1"	bar	drain system	easy fill	handle	table mounting	19l tank	automatic ON/OFF	residual water
600P		●	●									
800X		●	●									
1100X		●	●									

Con autoclave With booster unit

600PB			●	●								
800XB			●	●								
1100XB			●	●								

Immersione Submersible

250PC						●	●	●				
400PC						●	●	●				
750XC						●	●	●				
750PT						●	●	●	●	●	●	●
1100XD										●	●	●

POMPE AUTOADESCANTI *SELF-PRIMING* *PUMPS*

Le pompe autoadescanti della gamma Annovi Reverberi forniscono la condizione ideale per una crescita rigogliosa delle piante e garantisce una conveniente fornitura di acqua di servizio per la casa e il giardino.

Consentono il recupero dell'acqua attingendo da fonti alternative come pozzi o bacini, per sistemi di irrigazione fissi o mobili, oppure per riempire piscinette o fontane.

Grazie al sistema di risparmio energetico ON/OFF, le pompe offrono una soluzione sostenibile e rispettosa dell'ambiente.

Annovi Reverberi's self-priming jet pumps range provides the ideal condition for the lush growth of the garden plants and grants a convenient service water supply for home and garden.

It allows water recycling especially useful for fixed or mobile irrigation systems or to fill small pools or fountains, by drawing from alternative sources such as wells or basins.

Thanks to the energy saving ON / OFF system, the pumps offer a sustainable and environment friendly solution.





ARGP Series 600P

POMPE AUTOADESCANTI
self-priming pumps

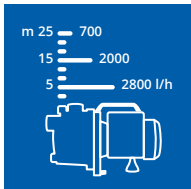

sistema di
riempimento
filling system

impugnatura ergonomica
hand grip handle

sistema di
svuotamento rapido
quick emptying system





Caratteristiche Generali



- La portata max. da 3100 l/h offre alte prestazioni
- Basso consumo energetico
- Autoadescante
- Protezione motore dalle alte temperature

General Features

- 3100 l/h max. flow rate offers high performance
- Low power consumption
- Self priming
- Motor protection at high temperatures



MOD	COD					
		V	Hz	W	m	l/h
600P	51986	230~	50	600	35	3100

		
T(Max)	IP X	kg NET
35°C	4	6,3

Accessori opzionali Optional accessories



46489



46491
(1L)

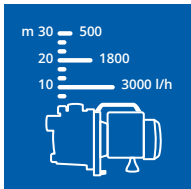

impugnatura ergonomica
hand grip handle

testata in acciaio
stainless steel head

Caratteristiche Generali

- La portata max. da 3500 l/h offre alte prestazioni
- Autoadescante
- Protezione motore dalle alte temperature

General Features

- 3500 l/h max. flow rate offers high performance
- Self-priming
- Motor protection at high temperatures



MOD	COD					
		V	Hz	W	m	l/h
800X	51988	230~	50	800	38	3500

T(Max)	IP X	kg NET
35°C	4	6,5

Accessori opzionali Optional accessories



46489



46491
(1L)



ARGP Series 1100X

POMPE AUTOADESCANTI
self-priming pumps

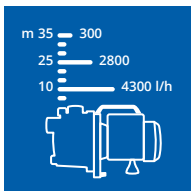

testata in acciaio
stainless steel head

impugnatura ergonomica
hand grip handle

Caratteristiche Generali

- La portata max. da 4600 l/h offre alte prestazioni
- Motore performante
- Protezione motore dalle alte temperature

General Features

- 4600 l/h max. flow rate offers high performance
- Powerful motor
- Motor protection at high temperatures



MOD	COD					
		V	Hz	W	m	l/h
1100X	51990	230~	50	1100	45	4600

T(Max)	IP X	kg NET
35°C	4	9,1

Accessori opzionali Optional accessories



46489



46491
(1L)



POMPE AUTOADESCANTI CON AUTOCLAVE *SELF-PRIMING PUMPS WITH BOOSTER UNIT*

Le pompe autoadescenti con autoclave della serie AR Blue Clean forniscono acqua da utilizzare con elettrodomestici, sanitari o per l'irrigazione del giardino, mantenendo una pressione stabile e costante.

Le pompe si integrano con l'approvvigionamento idrico domestico, per l'utilizzo dell'acqua piovana, di serbatoi o di pozzi, evitando lo spreco di acqua potabile.

Grazie al sistema di risparmio energetico ON/OFF, queste pompe offrono una soluzione sostenibile e rispettosa dell'ambiente.

The self-priming pumps with pressure tank, provided by Annovi Reverberi, excel at supplying water for domestic clean water fixtures or for garden irrigation, maintaining a stable and constant pressure.

The pumps can be integrated with domestic water supply systems, since their use of rainwater, drawn from tanks or wells, prevents the waste of drinking water.

Thanks to the energy saving ON/OFF system, the pumps offer a sustainable and environment friendly solution.





ARGP Series 600PB

**POMPE AUTOADESCANTI
CON AUTOCLAVE**
self-priming pumps with booster unit



riempimento
pompa facilitato
 pump easy fill

impugnatura
ergonomica
 hand grip handle

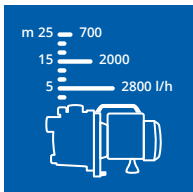
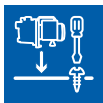

ON/OFF automatico
 automatic ON/OFF



Caratteristiche Generali

- La portata max. da 3100 l/h offre alte prestazioni
- Serbatoio 19L in acciaio
- Interruttore automatico ON/OFF
- Protezione motore dalle alte temperature

General Features

- 3100 l/h max. flow rate offers high performance
- 19L steel pressure tank
- Automatic ON/OFF switch
- Motor protection at high temperatures



MOD	COD					
		V	Hz	W	m	l/h
600PB	51987	230~	50	600	35	3100

T(Max)	IP X	kg NET
35°C	4	10,8

Accessori opzionali *Optional accessories*



46489



46492
(2L)

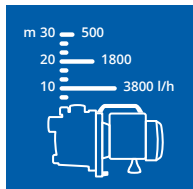
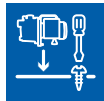

Caratteristiche Generali

- La portata max. da 3500 l/h offre alte prestazioni
- Serbatoio 19L in acciaio
- Interruttore automatico ON/OFF
- Protezione motore dalle alte temperature

General Features

- 3500 l/h max. flow rate offers high performance
- 19L steel pressure tank
- Automatic ON/OFF switch
- Motor protection at high temperatures

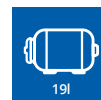
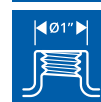

MOD	COD					
		V	Hz	W	m	l/h
800XB	51989	230~	50	800	38	3500

T(Max)	IP X	kg NET
35°C	4	10,9

Accessori opzionali Optional accessories



46489



46492
(2L)



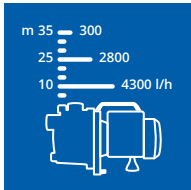
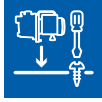

Caratteristiche Generali

- La portata max. da 4600 l/h offre alte prestazioni
- Motore performante
- Serbatoio 24L in acciaio
- Interruttore automatico ON/OFF
- Protezione motore dalle alte temperature

General Features

- 4600 l/h max. flow rate offers high performance
- Powerful motor
- 24L steel pressure tank
- Automatic ON/OFF switch
- Motor protection at high temperatures

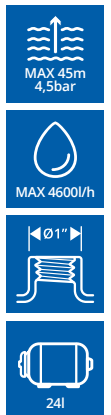

MOD	COD	V	Hz	W	m	l/h
1100XB	51991	230~	50	1100	45	4600

T(Max)	IP X	kg NET
35°C	4	14,1

Accessori opzionali Optional accessories



46489



46492
(2L)

POMPE AD IMMERSIONE *SUBMERSIBLE PUMPS*

Elimina ogni residuo di acqua!
Le pompe ad immersione della gamma AR Blue Clean spostano grandi quantità di acqua in poco tempo, fino a 16000 litri all'ora. Le pompe possono essere utilizzate per trasportare acqua pulita o sporca. Il design innovativo consente all'utente di rimuovere l'acqua lasciando solo 5mm di acqua residua sulla superficie piana. Il caratteristico interruttore a galleggiante consente di avviare automaticamente le pompe quando necessario.

*Get rid of any water residue!
Annovi Reverberi submersible pumps move large volumes of water in a short time, up to 16000 liters per hour. They can be used to pump out clean or dirty water. The innovative design allows the user to remove the water leaving only 5mm of residual water on the flat surface. The characteristic float switch allows the pumps to be started automatically whenever necessary.*





G 1" 1/2 - 38 mm
G 1" - 25 mm
Ø 1" - 25 mm
Ø 1" 1/4 - 32 mm

galleggiante con sistema
di accensione/spegnimento
float with ON/OFF system

acque pulite
clean water

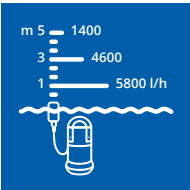

Caratteristiche Generali

- Motore a basso consumo
- Interruttore a galleggiante integrato
- 5 mm min. di livello di aspirazione
- Protezione motore dalle alte temperature

General Features

- Low consumption motor
- Integrated float switch
- 5mm minimum suction level
- Motor protection at high temperatures

250 PC



400PC



MOD	COD					
		V	Hz	W	m	l/h
250PC	51982	230~	50	250	6	6000
400PC	52172	230~	50	400	8	7000

T(Max)	IP X	kg NET
35°C	8	3,7
35°C	8	4,2

Accessori opzionali Optional accessories



46490

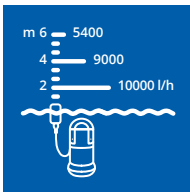
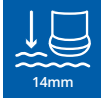

G 1"1/2 - 38 mm
G 1" - 25 mm
Ø 1" - 25 mm
Ø 1" 1/4 - 32 mm

acque pulite
clean water



galleggiante con sistema
di accensione/spengimento
float with ON/OFF system

Caratteristiche Generali

- Design compatto
- Corpo in acciaio inox resistente alla corrosione
- Protezione motore dalle alte temperature

General Features

- Compact design
- Corrosion-resistant stainless steel body
- Motor protection at high temperatures



MOD	COD	V	Hz	W	m	l/h
750XC	51984	230~	50	750	8,5	11000

T(Max)	IP X	kg NET
35°C	8	5

Accessori opzionali Optional accessories



46490



ARUP Series 750PT

POMPE AD IMMERSIONE
submersible pumps

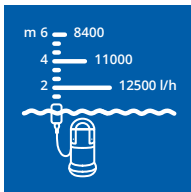

G 1" 1/2 - 38 mm
G 1" - 25 mm
Ø 1" - 25 mm
Ø 1" 1/4 - 32 mm

altezza variabile
per il passaggio
di acqua pulita/sporca
*variable height for passage
of clean/dirty water*



galleggiante con sistema
di accensione/spengimento
float with ON/OFF system

Caratteristiche Generali

- Interruttore a galleggiante integrato
- Piedi pieghevoli per variare l'aspirazione da acque chiare a scure
- Protezione motore dalle alte temperature

General Features

- *Integrated float switch*
- *Folding legs to swith from clean to dirty water suction*
- *Motor protection at high temperatures*



MOD	COD					
		V	Hz	W	m	l/h
750PT	51983	230~	50	750	8	13000

T(Max)	IP X	kg NET
35°C	8	5,24

Accessori opzionali *Optional accessories*



46490

Sistema multifunzione.

Multifunction system.



MODALITÀ ACQUA SPORCA

Aperto i piedi della pompa si ha la possibilità di drenare acque molto sporche con residui di diametro fino a 30 mm.

DIRTY WATER MODE

Unfolding the pump feet you can drain very dirty water with residues up to 30mm in diameter.

MODALITÀ ACQUA PULITA

Con i piedi chiusi la pompa consente il drenaggio di acqua pulita lasciando un residuo di soli 5 mm.

CLEAN WATER MODE

Folding the pump feet allows you the drainage of clean water leaving a residue of only 5 mm.



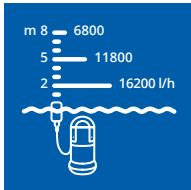

G 1" 1/2 - 38 mm
G 1" - 25 mm
Ø 1" - 25 mm
Ø 1" 1/4 - 32 mm

acque sporche
dirty water

galleggiante con sistema
di accensione/spegnimento
float with ON/OFF system



Caratteristiche Generali

- Motore performante
- Corpo in acciaio inox resistente alla corrosione
- Protezione motore dalle alte temperature

General Features

- Powerful motor
- Corrosion-resistant stainless steel body
- Motor protection at high temperatures







MOD	COD	V	Hz	W	m	l/h
1100XD	51985	230~	50	1100	10,5	16500

T(Max)	IP X	kg NET
35°C	8	6,6

Accessori opzionali Optional accessories



46490

			Autoascanti <i>Self-priming</i>			Con autoclave <i>With booster unit</i>			Immersione <i>Submersible</i>				
			600P	800X	1100X	600PB	800XB	1100XB	250PC	400PC	750XC	750PT	1100XD
Tubo di aspirazione <i>Suction hose</i>		46489	<input type="radio"/>	<input type="radio"/>	<input type="radio"/>	<input type="radio"/>	<input type="radio"/>	<input type="radio"/>					
Tubo di mandata <i>Delivery hose</i>		46490							<input type="radio"/>	<input type="radio"/>	<input type="radio"/>	<input type="radio"/>	<input type="radio"/>
Prefiltro <i>Water filter</i>		46491 (1L)	<input type="radio"/>	<input type="radio"/>	<input type="radio"/>								
Prefiltro <i>Water filter</i>		46492 (2L)				<input type="radio"/>	<input type="radio"/>	<input type="radio"/>					







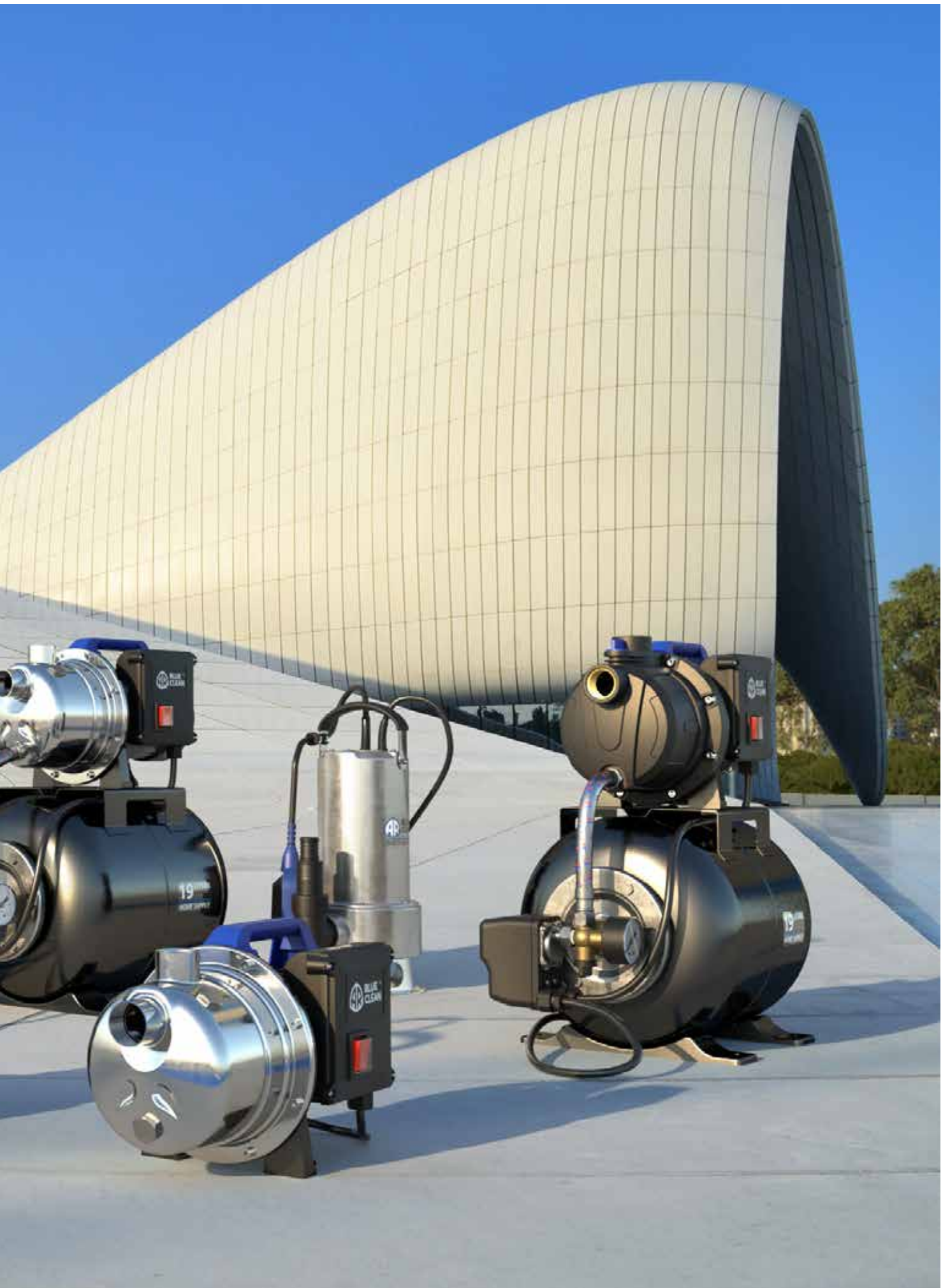

MERCHAN- DISING



AR Blue Display

MERCHANDISING
merchandising



A

**ESPOSITORI
EXHIBITORS**



B

DETERGENT DISPLAY



C

**BANDIERE
FLAGS**



D

TOTEM

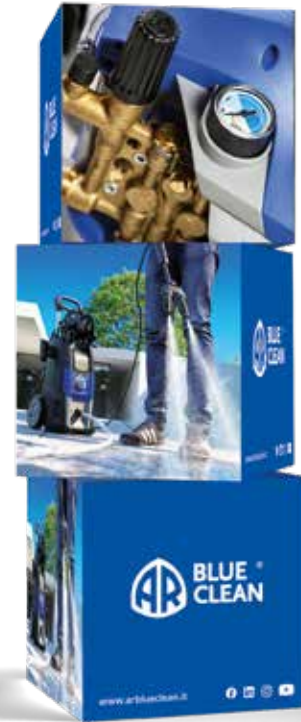

E

**CUBI
CUBES**



F

CORNER



G

CORNER DISPLAY



H

TESTER

Adatti per allestire punti vendita, showroom ed insegne, i supporti in cartotecnica realizzati a marchio ARBC, hanno una buona resistenza all'usura e possono essere utilizzati sia per uso interno che esterno.

Lo spazio di un negozio non può essere neutrale, per questo i supporti alla vendita a marchio ARBC sono stati progettati in base alle necessità del punto vendita stesso, permettendo così di trovare il giusto punto di incontro fra l'offerta e la percezione che il cliente ne può avere.

Un punto vendita accogliente ed invitante infatti è fondamentale per mettere a proprio agio i clienti e incentivarli all'acquisto, è per questo che Annovi Reverberi ha deciso di mettere in risalto i prodotti nei diversi punti vendita unendo estetica e funzionalità.

Suitable for point of sale and showroom outfitting and for signs, ARBC brand cardboard sales tools are hard-wearing and can be used both indoors and outdoors.

A store space cannot be anonymous, and so ARBC sales tools are designed specifically for the point of sale's needs, establishing the right connection between the offering and the customer's perception of it.

An attractive, inviting point of sale is fundamental for putting customers at their ease and encouraging them to purchase, and so Annovi Reverberi has chosen this stylish yet very practical means of highlighting its products in the various points of sale.

Dati Tecnici / Technical Data

MOD	REF	COD	DIMENSIONS mm (LxWxH)	kg	N° PEZZI
AR Blue Display	A	900000026	530x541X2231	26	1
Detergent Display	B	900000027	440x305x1580	4,5	64
AR Flag	C	900000018	780x600x2380	2,0	1
AR Totem	D	900000220	430X200X1530	0,7	1
AR Cubes	E	900000218	420X420X420	0,9	1
AR Corner	F	900000162	400X300X1800	7,5	1
AR Corner Display	G	900000163	400X300X1800	8,5	1
AR Tester	H	900000164	400X330X750	9,0	1

AR BLUE CLEAN

2X 2 POWER UNITS, DOUBLE CLEANING

2X

SYSTEM

WPP

FAST



arblueclean.it

arblueclean.it

AR BLUE CLEAN



2X 2 POWER UNITS,
DOUBLE
CLEANING



arblueclean.it

AR BLUE CLEAN



www.arblueclean.it



LOGISTIC DATA

Dati logistici



Index

DATI LOGISTICI
logistic data



20"

40"



Modello Model	AR code	EAN code	Dimensione scatola Box dimensions	Dimensioni esterne Outer dimensions	Q.ty pallet n°	Container		Camion Full Truck n°	Peso Weight Kg	Pag.
			(L x W x H) mm	(L x W x H) mm		20 ft n°	40 ft n°			
117	13689	8016287136891	260x235x470	220x235x460	60*	1050~	2145~	1980	6,2	18
143	13690	8016287136907	300x235x470	280x240x650	48*	903~	1818~	1452	7	19
387	15458	8016287154581	315x283x500	280x253x705	32*	646	1298	1056	9,0	20
397	15459	8016287154598	315x283x730	280x253x705	16*	420	840	528	11,1	21
491	13694	8016287136945	590x375x568	420x360x930	12*	228~	468~	396	23,7	22
589	14989	8016287149891	420x395x770	449x388x895	10*	210~	435~	330	27,2	24
591	14990	8016287149907	420x395x770	449x388x895	10*	210~	435~	330	28	25
2.0	14986	8016287149860	360x340x815	330x307x790	12*	288~	576~	396	13,1	31
3.0	14988	8016287149884	360x340x815	330x307x790	12*	288~	576~	396	13,4	32
2.A	15153	8016287151535	360x340x815	330x307x790	12*	288~	576~	396	13,8	37
4.0	14792	8016287147927	420x395x770	449x388x895	10*	210~	435~	330	16,7	41
5.0	14793	8016287147934	420x395x770	449x388x895	10*	210~	435~	330	17,3	42
4.1Wi-Touch	15180	8016287151801	420x395x770	449x388x895	10*	210~	435~	330	17,3	47
7.0	15343	8016287153430	420x395x770	449x388x895	10*	210~	435~	330	28,9	51
BC250 DSS	15389	8016287153898	355x285x122	906x78x287	96	1728	3840	2496	3,5	55
611	15167	8016287151672	507x267x330	428X269x258	24*	672~	1407~	792	22,7	85
613	13975	8016287139755	300x500x420	434x275x263	12*	264	576	792	20,3	86
614	13977	8016287139779	300x500x420	434x275x263	12*	264	576	792	23	86
613 K	13976	8016287139762	485x495x600	449x452x806	12	66	150	312	29,2	87
614 K	13978	8016287139786	485x495x600	449x452x806	12	66	150	312	31,7	87
630	12360	8016287123600	530x280x340	390x240x230	24*	264	600	792	29	90
630 K	14633	8016287146333	485x495x600	449x452x905	12	66	150	312	35,9	90
670	14680	8016287146807	507x267x330	380X239x260	24*	672~	1407~	792	22	91
671	14697	8016287146975	507x267x330	380X239x260	24*	672~	1407~	792	25,8	91
680	15267	8016287152679	507x267x330	428X269x258	24*	672~	1407~	792	23,4	92
680 K	15268	8016287152686	485x495x600	449X452x905	12	66	150	312	27,5	92
930	14261	8016287142618	705x540x720	800x480x980	4*	66	138	132	50	97
960	15479	8016287154796	705x540x720	800x480x980	4*	66	138	132	52	97
980	15480	8016287154802	705x540x720	800x480x980	4*	66	138	132	62	97
1003 K	25543	8016287255431	485x495x600	460x460x810	12	66	150	312	42,2	100
1005 K	15500	8016287155007	487x495x600	460x460x810	6*	66	150	198	44,2	100
1001	24384	8016287243841	725x490x770	670x490x900	4*	60	120	132	35,9	101
1003	24385	8016287243858	725x490x770	670x490x900	4*	60	120	132	40,6	102
1003 RLW	24389	8016287243896	725x490x770	670x540x900	4*	60	120	132	53	102
1003 XE	15165	8016287151658	725x490x770	670x540x900	4*	60	120	132	49,7	102



20"

40"



Modello Model	AR code	EAN code	Dimensione scatola Box dimensions	Dimensioni esterne Outer dimensions	Q.ty pallet n°	Container		Camion Full Truck n°	Peso Weight Kg	Pag.
			(L x W x H) mm	(L x W x H) mm		20 ft n°	40 ft n°			
1006XE	15475	8016287154758	725x490x770	670x540x900	4*	60	120	132	51	102
1007	25150	8016287251501	725x490x770	670x490x900	4*	60	120	132	64	103
1007 RLW	25304	8016287253048	725x490x770	670x540x900	4*	60	120	132	67,7	103
1007 XE	15166	8016287151665	725x490x770	670x540x900	4*	60	120	132	64	103
1009RLW	15254	8016287153546	725x490x770	670x540x900	4*	60	120	132	69	104
1015	25283	8016287252836	600x860x630	580x1020x830	6	66	150	198	77	105
1018	24491	8016287244916	600x860x630	580x1020x830	6	66	150	198	88	106
1018H	25272	8016287252720	600x860x630	580x1020x830	6	66	150	198	88	107
1120	22374	8016287223744	730x1130x760	650x1250x900	2	22	50	66	118	108
1415	26213	8016287262132	520x440x520	460x460x480	12*	228~	456~	264	19,8	113
1425	26215	8016287262156	510x590x565	650x505x890	6*	168~	340~	198	29,6	114
1435	26406	8016287264068	520x690x565	771x458x926	6*	140~	296~	198	35,1	115
1440	26216	8016287262163	520x690x565	771x458x926	6*	140~	296~	198	35,8	116
1445	26407	8016287264075	520x690x565	771x458x926	6*	140~	296~	198	36,1	117
1445 XE	27856	8016287278560	520x690x565	771x458x926	6*	140~	296~	198	36,1	117
1447	26578	8016287265782	520x690x565	770x480x890	12*	140	292	198	39,1	118
1450	26217	8016287262170	520x690x565	771x458x926	6*	140~	296~	198	39,1	119
1460	26218	8016287262187	830x595x690	900x530x900	4*	75~	162~	132	56,8	120
1475	26325	8016287263252	830x595x640	900x530x900	6*	72~	153~	198	64,1	120
1475 XE	27857	8016287278577	830x595x640	900x530x900	6*	72~	153~	198	64,1	120
1480	26219	8016287262194	830x595x690	900x530x900	4*	75~	162~	132	64,9	120
1490	26408	8016287264082	830x595x690	900x530x900	4*	75~	162~	132	64	121
2591	15376	8016287153768	510x770x700	500x730x920	6*	99	207	198	47	142
3590	24425	8016287244251	510x770x700	500x730x920	6*	99	207	198	53	142
4590	24426	8016287244268	510x770x700	500x730x920	6*	99	207	198	54	142
5670	25671	8016287256711	570x780x850	540x800x750	4	44	100	132	88	144
5850	25672	8016287256728	570x780x850	540x800x750	4	44	100	132	94	145
5870	25673	8016287256735	570x780x850	540x800x750	4	44	100	132	94	145
6640	25275	8016287252751	740x1140x1100	1000x570x820	1	30	64	72	112	146
6670	25288	8016287252881	740x1140x1100	1000x570x820	1	30	64	72	115	146
6950	24103	8016287241038	740x1140x1100	980x590x920	1	30	64	72	138	147
6970	25276	8016287252768	740x1140x1100	980x590x920	1	30	64	72	138	147
7850	25277	8016287252775	740x1140x1100	980x590x920	1	30	64	72	138	148
7870	25278	8016287252782	740x1140x1100	980x590x920	1	30	64	72	145	148
8840	22913	8016287229132	740x1140x1140	1100x700x1040	1	30	64	72	173	149

~ Floor loaded / sfuso
• Europallet









Index

DATI LOGISTICI
logistic data



Modello Model	AR code	EAN code	Dimensione scatola Box dimensions	Dimensioni esterne Outer dimensions	Q.ty pallet n°	Container		Camion Full Truck n°	Peso Weight Kg	Pag.
			(L x W x H) mm	(L x W x H) mm		20 ft n°	40 ft n°			
8860	22914	8016287259149	740x1140x1140	1100x700x1040	1	30	64	72	180	149
8880	22915	8016287229159	740x1140x1140	1100x700x1040	1	30	64	72	174	149
1310	24894	8016287248945	730x1130x760	1100x650x700	2	22	50	66	103	150
1320	25273	8016287252737	730x1130x760	1100x650x700	2	22	50	66	103	150
1325	25274	8016287252744	730x1130x760	1100x650x700	2	22	50	66	103	150
1380	25284	8016287252843	760x1160x1080	1180x730x960	1	30	60	68	174	151
3170	51922-V	8016287519229	380x355x405	346x339x385	30°	552~	1140~	990	6,4	164
3270	51923-V	8016287519236	380x355x533	346x339x509	18°	412~	856~	792	7,0	165
3370	51924-V	8016287519243	410x410x485	415x415x473	24°	431~	864~	792	8,1	166
3670	51927-V	8016287519274	410x410x575	415x415x554	18°	359~	720~	594	8,4	167
3770	51928-V	8016287519281	495x460x570	465x444x560	6°	239~	488~	198	11,7	168
3780	51929-V	8016287519298	625x575x645	538x683x852	6°	108~	228~	198	16,8	169
E12	52445	8016287524452	260x260x340	250x250x330	60°	1158	2432	1188	3,1	170
M20	52013	8016287520133	410x410x485	415x415x473	24°	339	688	792	8,9	171
4100	50180	8016287511803	415x415x580	400x400x900	18°	280	560	594	12	178
4200	50181	8016287511810	415x415x580	400x400x800	15°	168	336	495	13,7	179
4200 P	51061	8016287510615	415x415x580	415x415x875	15°	168	336	495	12,6	180
4300MP	52507	8016287525077	415x415x800	400x400x800	15°	168	336	495	24	181
4400MP	52508	8016287525084	415x415x800	400x400x800	15°	168	336	495	27,5	181
4300 P	52509	8016287525091	590x615x1060	600x600x1100	4°	54	120	133	22	182
4400 P	52510	8016287525107	590x615x1060	600x600x1100	4°	54	120	133	27	182
4300	52511	8016287525114	590x615x1060	600x600x1100	4°	54	120	133	24	183
4400	52512	8016287525121	590x615x1060	600x600x1100	4°	54	120	133	29	184
4700 S	51065	8016287510653	415x415x800	600x600x1100	15°	168	336	495	14	185
4800	51203	8016287512039	410x410x810	600x600x1100	15°	175	362	495	13,9	186
4200 L	51289	8016287512893	415x415x820	400x400x800	15°	168	336	495	14	187
4300 L	51205	8016287512053	590x615x1060	620x620x1000	4°	54	120	133	27,5	188
4900	51067	8016287510677	500x600x1060	590x550x1040	4°	84	176	133	29,8	189
600P	51986	8016287519861	370x225x260	340x210x210	72°	1100~	2260~	*	7,4	208
800X	51988	8016287519885	370x225x260	340x210x210	72°	1030~	2115~	*	7,8	209
1100X	51990	8016287519908	410x250x280	380x220x225	49°	1030~	2115~	*	10,4	210
600PB	51987	8016287519878	485x300x550	440x270x510	18°	350~	730~	*	11,8	214
800XB	51989	8016287519892	485x300x550	440x270x510	18°	350~	730~	*	12,2	215
1100XB	51991	8016287519915	520x300x560	500x270x530	12°	335~	690~	*	15,4	217
250PC °	51982	8016287519823	220x160x330	165x158x305	100°	1864~	3436~	*	4,4	220



Modello Model	AR code	EAN code								Pag.
			Dimensione scatola Box dimensions	Dimensioni esterne Outer dimensions	Q.ty pallet	Container		Camion	Peso	
			(L x W x H) mm	(L x W x H) mm	n°	20 ft	40 ft	Full Truck	Weight	
						n°	n°	n°	Kg	
400PC [◇]	52172	8016287521727	220x160x330	165x158x305	100 [*]	1864 [~]	3436 [~]	*	4,9	220
750XC [◇]	51984	8016287519847	220x180x340	150x150x312	80 [*]	1864 [~]	3436 [~]	*	5,6	221
750PT [◇]	51983	8016287519830	220x160x360	167x160x357	100 [*]	1672 [~]	3432 [~]	*	5,8	222
1100XD [◇]	51985	8016287519854	220x180x385	187x167x382	80 [*]	1588 [~]	3264 [~]	*	7,2	225

* Dati disponibili su richiesta / Data available on request

[◇] Fornito in master box con 4 pezzi /

Supplied in masterbox with 4 pcs

[~] Floor loaded / sfuso

• Europallet



Idropultrici High Pressure Washers



Applicazioni Applications	cancellate fencing panchine benches giardino garden biciclette bicycles moto motorcycle auto cars camper recreational vehicles RV's, campers barche boats pavimenti flooring, paving stones scale stairs piscine pools utensili tools casa house muri walls tetti roofs disinfestazione zanzare pest control gardening igienizzazione superfici sanitizing edilizia construction agricoltura zootecnica agriculture zootechy artigianato crafts car wash automotive
Tecniche Technical	pressione massima max pressure portata massima max flow rate potenza assorbita absorbed power peso netto net weight motore universale universal engine motore benzina gasoline engine pompa a piattello wobble plate pump pompa a bielle rod-crank pump testa in ottone brass head testa in alluminio aluminum head testa nichelata nichel plated head temperatura massima max temperature resistenza all'acqua water resistance giunto elastico flex coupling sistema doppia pompa double pump system sistema doppia velocità double speed system sistema doppia funzione double function system acqua fredda cold water acqua calda hot water regolatore pressione pressure adjustment TSS Total Stop SYSTEM TST Total Stop SYSTEM TIMED SPF Self Priming FUNCTION funzione autoadescente self priming function
Funzioni Functions	+50% WPP prestazioni lavaggio washing performance power +70% FASTER risparmio tempo time savings Up to 5m altezza raggiungibile reachable height

Aspiratori Vacuums





Applicazioni Applications	liquidi fluids grandi volumi big volumes interni houses cantine cellars soffitte lofts autorimesse garages balconi balcony cucce dog house, kennels piccoli cantieri little work sites veicoli cars poltrone divani armchairs couches spazi ristretti limited spaces stufe heaters camini fireplaces griglie grills edilizia construction agricoltura zootecnica agriculture zootechy artigianato crafts car wash automotive
Tecniche Technical	potenza assorbita absorbed power peso netto net weight n° motori engines n° stadi motore engine stages depressione vacuum pressure aria aspirata air flow rate rumorosità loudness capacità fusto capacity diametro accessori accessory diameter tempo di utilizzo working time tempo di ricarica recharging time
Funzioni Functions	aspirazione liquidi liquid suction aspirazione polveri dust suction funzione soffiante blow function aspirazione cenere ash suction presa elettro-utensile power tool socket suction

Pompe Water Pumps



Applicazioni Applications	irrigazione manuale manual irrigation irrigazione automatica automatic irrigation acque per i servizi water supply allagamenti domestici house flooded pozzetti wells piscine swimming pools cantieri construction sites stagni/laghetti ponds allagamenti floodings
Tecniche Technical	pressione massima/prevalenza max pressure/height portata massima max flow dimensioni di montaggio fitting dimensions ON/OFF automatico automatic ON/OFF sistema di scarico drain system facile riempimento easy fill impugnatura ergonomica handle montaggio da tavolo table mounting serbatoio tank ON/OFF automatico automatic ON/OFF acqua residua residual water dimensione massima particolato max grain size altezza variabile variable height corpo in acciaio inossidabile stainless steel body testata pompa in acciaio inossidabile stainless steel pump head portata massima max flow rate potenza assorbita absorbed power peso netto net weight temperatura massima max temperature resistenza all'acqua water resistance
Funzioni Functions	adatto ad acque pulite suitable for clean water adatto ad acque sporche suitable for dirty water

Performance











OLIGHTPRO **HEAVYPRO**

Generiche Generic

 **plug&play**
 **novità new**
 **trade selection**
 **2in1 Washer Sprayer**

Logistiche Logistics

 **euro pallet euro pallet**
 **full track full truck**
 **20"**
 **40"**
 **dimensioni packaging dimension packaging**
 **dimensioni macchina dimension machine**
 **peso lordo gross weight**



**BLUE[®]
CLEAN**

Annovi Reverberi spa

Via Martin L. King 3
41122 Modena (Italy)
Tel +39 059 414 411
info@arblueclean.it
www.arblueclean.it

AR North America Inc.

140 - 81st Avenue Northeast
Fridley, MN USA 55432
Ph. +1 763 398 2008
Fax +1 763 398 2009
info@arnorthamerica.com
www.arnorthamerica.com

AR China Distribution Co., Ltd

2nd Floor, Building 1, No. 651 Jiangting Rd.
Jinhui Town, Fengxian District, Shanghai
201404 China
Ph. +86 21 54846800
Fax +86 21 54846800 ext 815
info@ar-china.cn
www.ar-china.cn

© 2023 Annovi Reverberi